



Aircraft Metals

Knowledge and understanding of the uses, strengths, limitations, and other characteristics of structural metals is vital to properly construct and maintain any equipment, especially airframes. In aircraft maintenance and repair, even a slight deviation from design specification, or the substitution of inferior materials, may result in the loss of both lives and equipment. The use of unsuitable materials can readily erase the finest craftsmanship. The selection of the correct material for a specific repair job demands familiarity with the most common physical properties of various metals.

Properties of Metals

Of primary concern in aircraft maintenance are such general properties of metals and their alloys as hardness, malleability, ductility, elasticity, toughness, density, brittleness, fusibility, conductivity contraction and expansion, and so forth. These terms are explained to establish a basis for further discussion of structural metals.

Hardness

Hardness refers to the ability of a material to resist abrasion, penetration, cutting action, or permanent distortion. Hardness may be increased by cold working the metal and, in the case of steel and certain aluminum alloys, by heat treatment. Structural parts are often formed from metals in their soft state and are then heat treated to harden them so that the finished shape will be retained. Hardness and strength are closely associated properties of metals.

Strength

One of the most important properties of a material is strength. Strength is the ability of a material to resist deformation. Strength is also the ability of a material to resist stress without breaking. The type of load or stress on the material affects the strength it exhibits.

Density

Density is the weight of a unit volume of a material. In aircraft work, the specified weight of a material per cubic inch is preferred since this figure can be used in determining the weight of a part before actual manufacture. Density is an important consideration when choosing a material to be used in the design of a part in order to maintain the proper weight and balance of the aircraft.

Malleability

A metal which can be hammered, rolled, or pressed into various shapes without cracking, breaking, or leaving some other detrimental effect, is said to be malleable. This property is necessary in sheet metal that is worked into curved shapes, such as cowlings, fairings, or wingtips. Copper is an example of a malleable metal.

Ductility

Ductility is the property of a metal which permits it to be permanently drawn, bent, or twisted into various shapes without breaking. This property is essential for metals used in making wire and tubing. Ductile metals are greatly preferred for aircraft use because of their ease of forming and resistance to failure under shock loads. For this reason, aluminum alloys are used for cowl rings, fuselage and wing skin, and formed or extruded parts, such as ribs, spars, and bulkheads. Chrome molybdenum steel is also easily formed into desired shapes. Ductility is similar to malleability.

Elasticity

Elasticity is that property that enables a metal to return to its original size and shape when the force which causes the change of shape is removed. This property is extremely valuable because it would be highly undesirable to have a part permanently distorted after an applied load was removed. Each metal has a point known as the elastic limit, beyond which it cannot be loaded without causing permanent distortion. In aircraft construction, members and parts are so designed that

the maximum loads to which they are subjected will not stress them beyond their elastic limits. This desirable property is present in spring steel.

Toughness

A material which possesses toughness will withstand tearing or shearing and may be stretched or otherwise deformed without breaking. Toughness is a desirable property in aircraft metals.

Brittleness

Brittleness is the property of a metal which allows little bending or deformation without shattering. A brittle metal is apt to break or crack without change of shape. Because structural metals are often subjected to shock loads, brittleness is not a very desirable property. Cast iron, cast aluminum, and very hard steel are examples of brittle metals.

Fusibility

Fusibility is the ability of a metal to become liquid by the application of heat. Metals are fused in welding. Steels fuse around 2,600°F and aluminum alloys at approximately 1,100°F.

Conductivity

Conductivity is the property which enables a metal to carry heat or electricity. The heat conductivity of a metal is especially important in welding because it governs the amount of heat that will be required for proper fusion. Conductivity of the metal, to a certain extent, determines the type of jig to be used to control expansion and contraction. In aircraft, electrical conductivity must also be considered in conjunction with bonding, to eliminate radio interference.

Thermal Expansion

Thermal expansion refers to contraction and expansion that are reactions produced in metals as the result of heating or cooling. Heat applied to a metal will cause it to expand or become larger. Cooling and heating affect the design of welding jigs, castings, and tolerances necessary for hot rolled material.

Ferrous Aircraft Metals

Many different metals are required in the repair of aircraft. This is a result of the varying needs with respect to strength, weight, durability, and resistance to deterioration of specific structures or parts. In addition, the particular shape or form of the material plays an important role. In selecting materials for aircraft repair, these factors plus many others are considered in relation to the mechanical and physical properties.

Among the common materials used are ferrous metals. The term “ferrous” applies to the group of metals having iron as their principal constituent.

Iron

If carbon is added to iron, in percentages ranging up to approximately 1 percent, the product is vastly superior to iron alone and is classified as carbon steel. Carbon steel forms the base of those alloy steels produced by combining carbon steel with other elements known to improve the properties of steel. A base metal (such as iron) to which small quantities of other metals have been added is called an alloy. The addition of other metals changes or improves the chemical or physical properties of the base metal for a particular use.

Steel and Steel Alloys

To facilitate the discussion of steels, some familiarity with their nomenclature is desirable. A numerical index, sponsored by the Society of Automotive Engineers (SAE) and the American Iron and Steel Institute (AISI), is used to identify the chemical compositions of the structural steels. In this system, a four-numeral series is used to designate the plain carbon and alloy steels; five numerals are used to designate certain types of alloy steels. The first two digits indicate the type of steel, the second digit also generally (but not always) gives the approximate amount of the major alloying element, and the last two (or three) digits are intended to indicate the approximate middle of the carbon range. However, a deviation from the rule of indicating the carbon range is sometimes necessary.

Small quantities of certain elements are present in alloy steels that are not specified as required. These elements are considered as incidental and may be present to the maximum amounts as follows: copper, 0.35 percent; nickel, 0.25 percent; chromium, 0.20 percent; molybdenum, 0.06 percent.

The list of standard steels is altered from time to time to accommodate steels of proven merit and to provide for changes in the metallurgical and engineering requirements of industry. [Figure 5-1]

Metal stock is manufactured in several forms and shapes, including sheets, bars, rods, tubing, extrusions, forgings, and castings. Sheet metal is made in a number of sizes and thicknesses. Specifications designate thicknesses in thousandths of an inch. Bars and rods are supplied in a variety of shapes, such as round, square, rectangular, hexagonal, and octagonal. Tubing can be obtained in round, oval, rectangular, or streamlined

Series Designation	Types
100xx	Nonsulphurized carbon steels
11xx	Resulphurised carbon steels (free machining)
12xx	Rephosphorized and resulphurised carbon steels (free machining)
13xx	Manganese 1.75%
*23xx	Nickel 3.50%
*25xx	Nickel 5.00%
31xx	Nickel 1.25%, chromium 0.65%
33xx	Nickel 3.50%, chromium 1.55%
40xx	Molybdenum 0.20 or 0.25%
41xx	Chromium 0.50% or 0.95%, molybdenum 0.12 or 0.20%
43xx	Nickel 1.80%, chromium 0.5 or 0.80%, molybdenum 0.25%
44xx	Molybdenum 0.40%
45xx	Molybdenum 0.52%
46xx	Nickel 1.80%, molybdenum 0.25%
47xx	Nickel 1.05% chromium 0.45%, molybdenum 0.20 or 0.35%
48xx	Nickel 3.50%, molybdenum 0.25%
50xx	Chromium 0.25, or 0.40 or 0.50%
50xxx	Carbon 1.00%, chromium 0.50%
51xx	Chromium 0.80, 0.90, 0.95 or 1.00%
51xxx	Carbon 1.00%, chromium 1.05%
52xxx	Carbon 1.00%, chromium 1.45%
61xx	Chromium 0.60, 0.80, 0.95%, vanadium 0.12%, 0.10% min., or 0.15% min.
81xx	Nickel 0.30%, chromium 0.40%, molybdenum 0.12%
86xx	Nickel 0.55%, chromium 0.50%, molybdenum 0.20%
87xx	Nickel 0.55%, chromium 0.05%, molybdenum 0.25%
88xx	Nickel 0.55%, chromium 0.05%, molybdenum 0.35%
92xx	Manganese 0.85%, silicon 2.00%, chromium 0 or 0.35%
93xx	Nickel 3.25%, chromium 1.20%, molybdenum 0.12%
94xx	Nickel 0.45%, chromium 0.40%, molybdenum 0.12%
98xx	Nickel 1.00%, chromium 0.80%, molybdenum 0.25%

*Not included in the current list of standard steels

Figure 5-1. SAE numerical index.

shapes. The size of tubing is generally specified by outside diameter and wall thickness.

The sheet metal is usually formed cold in such machines as presses, bending brakes, drawbenches, or rolls. Forgings are shaped or formed by pressing or

hammering heated metal in dies. Castings are produced by pouring molten metal into molds. The casting is finished by machining.

Spark testing is a common means of identifying various ferrous metals. In this test the piece of iron or steel is

held against a revolving grinding stone and the metal is identified by the sparks thrown off. Each ferrous metal has its own peculiar spark characteristics. The spark streams vary from a few tiny shafts to a shower of sparks several feet in length. (Few nonferrous metals give off sparks when touched to a grinding stone. Therefore, these metals cannot be successfully identified by the spark test.)

Identification by spark testing is often inexact unless performed by an experienced person, or the test pieces differ greatly in their carbon content and alloying constituents.

Wrought iron produces long shafts that are straw colored as they leave the stone and white at the end. Cast iron sparks are red as they leave the stone and turn to a straw color. Low carbon steels give off long, straight shafts having a few white sprigs. As the carbon content of the steel increases, the number of sprigs along each shaft increases and the stream becomes whiter in color. Nickel steel causes the spark stream to contain small white blocks of light within the main burst.

Types, Characteristics, and Uses of Alloyed Steels

Steel containing carbon in percentages ranging from 0.10 to 0.30 percent is classed as low carbon steel. The equivalent SAE numbers range from 1010 to 1030. Steels of this grade are used for making such items as safety wire, certain nuts, cable bushings, or threaded rod ends. This steel in sheet form is used for secondary structural parts and clamps, and in tubular form for moderately stressed structural parts.

Steel containing carbon in percentages ranging from 0.30 to 0.50 percent is classed as medium carbon steel. This steel is especially adaptable for machining or forging, and where surface hardness is desirable. Certain rod ends and light forgings are made from SAE 1035 steel.

Steel containing carbon in percentages ranging from 0.50 to 1.05 percent is classed as high carbon steel. The addition of other elements in varying quantities adds to the hardness of this steel. In the fully heat-treated condition it is very hard, will withstand high shear and wear, and will have little deformation. It has limited use in aircraft. SAE 1095 in sheet form is used for making flat springs and in wire form for making coil springs.

The various nickel steels are produced by combining nickel with carbon steel. Steels containing from 3 to 3.75 percent nickel are commonly used. Nickel increases the hardness, tensile strength, and elastic limit

of steel without appreciably decreasing the ductility. It also intensifies the hardening effect of heat treatment. SAE 2330 steel is used extensively for aircraft parts, such as bolts, terminals, keys, clevises, and pins.

Chromium steel is high in hardness, strength, and corrosion resistant properties, and is particularly adaptable for heat-treated forgings which require greater toughness and strength than may be obtained in plain carbon steel. It can be used for such articles as the balls and rollers of antifriction bearings.

Chrome-nickel or stainless steels are the corrosion resistant metals. The anticorrosive degree of this steel is determined by the surface condition of the metal as well as by the composition, temperature, and concentration of the corrosive agent. The principal alloy of stainless steel is chromium. The corrosion resistant steel most often used in aircraft construction is known as 18-8 steel because of its content of 18 percent chromium and 8 percent nickel. One of the distinctive features of 18-8 steel is that its strength may be increased by cold working.

Stainless steel may be rolled, drawn, bent, or formed to any shape. Because these steels expand about 50 percent more than mild steel and conduct heat only about 40 percent as rapidly, they are more difficult to weld. Stainless steel can be used for almost any part of an aircraft. Some of its common applications are in the fabrication of exhaust collectors, stacks and manifolds, structural and machined parts, springs, castings, tie rods, and control cables.

The chrome-vanadium steels are made of approximately 18 percent vanadium and about 1 percent chromium. When heat treated, they have strength, toughness, and resistance to wear and fatigue. A special grade of this steel in sheet form can be cold formed into intricate shapes. It can be folded and flattened without signs of breaking or failure. SAE 6150 is used for making springs; chrome-vanadium with high carbon content, SAE 6195, is used for ball and roller bearings.

Molybdenum in small percentages is used in combination with chromium to form chrome-molybdenum steel, which has various uses in aircraft. Molybdenum is a strong alloying element. It raises the ultimate strength of steel without affecting ductility or workability. Molybdenum steels are tough and wear resistant, and they harden throughout when heat treated. They are especially adaptable for welding and, for this reason, are used principally for welded structural parts and assemblies. This type steel has practically replaced carbon steel in the fabrication of fuselage tub-

ing, engine mounts, landing gears, and other structural parts. For example, a heat-treated SAE X4130 tube is approximately four times as strong as an SAE 1025 tube of the same weight and size.

A series of chrome-molybdenum steel most used in aircraft construction is that series containing 0.25 to 0.55 percent carbon, 0.15 to 0.25 percent molybdenum, and 0.50 to 1.10 percent chromium. These steels, when suitably heat treated, are deep hardening, easily machined, readily welded by either gas or electric methods, and are especially adapted to high temperature service.

Inconel is a nickel-chromium-iron alloy closely resembling stainless steel (corrosion resistant steel, CRES) in appearance. Aircraft exhaust systems use both alloys interchangeably. Because the two alloys look very much alike, a distinguishing test is often necessary. One method of identification is to use an electrochemical technique, as described in the following paragraph, to identify the nickel (Ni) content of the alloy. Inconel has a nickel content greater than 50 percent, and the electrochemical test detects nickel.

The tensile strength of Inconel is 100,000 psi annealed, and 125,000 psi when hard rolled. It is highly resistant to salt water and is able to withstand temperatures as high as 1,600°F. Inconel welds readily and has working qualities quite similar to those of corrosion resistant steels.

Electrochemical Test

Prepare a wiring assembly as shown in Figure 5-2, and prepare the two reagents (ammonium fluoride and dimethylglyoxime solutions) placing them in separate dedicated dropper solution bottles. Before testing, you must thoroughly clean the metal in order for the electrolytic deposit to take place. You may use nonmetallic hand scrubbing pads or 320 to 600 grit “crocus cloth”

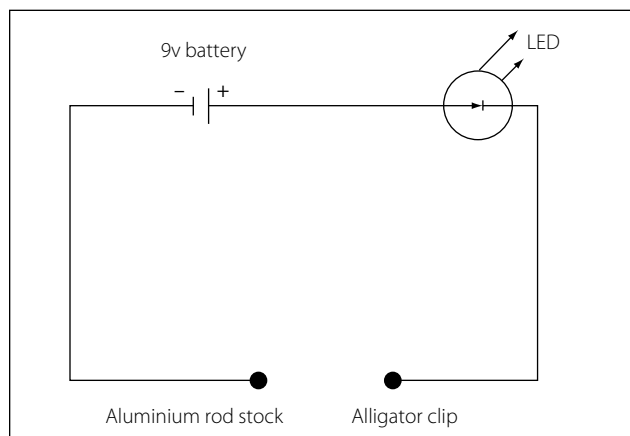

Figure 5-2. Wiring assembly schematic.

to remove deposits and corrosion products (thermal oxide).

Connect the alligator clip of the wiring assembly to the bare metal being tested. Place one drop of a 0.05 percent reagent grade ammonium fluoride solution in deionized water on the center of a 1 inch × 1 inch sheet of filter paper. Lay the moistened filter paper over the bare metal alloy being tested. Firmly press the end of the aluminum rod over the center of the moist paper. Maintain connection for 10 seconds while rocking the aluminum rod on the filter paper. Ensure that the light emitting diode (LED) remains lit (indicating good electrical contact and current flow) during this period. Disconnect the wiring assembly and set it aside. Remove the filter paper and examine it to determine that a light spot appears where the connection was made.

Deposit one drop of 1.0 percent solution of reagent grade dimethylglyoxime in ethyl alcohol on the filter paper (same side that was in contact with the test metal). A bright, distinctly pink spot will appear within seconds on the filter paper if the metal being tested is Inconel. A brown spot will appear if the test metal is stainless steel. Some stainless steel alloys may leave a very light pink color. However, the shade and depth of color will be far less than would appear for Inconel. For flat surfaces, the test spot will be circular while for curved surfaces, such as the outside of a tube or pipe, the test spot may appear as a streak. (Refer to Figure 5-3 for sample test results.) This procedure should not be used in the heat affected zone of weldments or on nickel coated surfaces.

Nonferrous Aircraft Metals

The term “nonferrous” refers to all metals which have elements other than iron as their base or principal constituent. This group includes such metals as alu-

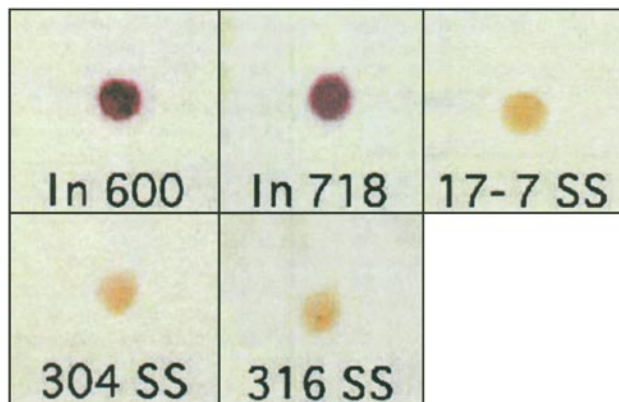

Figure 5-3. Electrochemical test results, Inconel and stainless steel alloys.

minum, titanium, copper, and magnesium, as well as such alloyed metals as Monel and babbit.

Aluminum and Aluminum Alloys

Commercially pure aluminum is a white lustrous metal which stands second in the scale of malleability, sixth in ductility, and ranks high in its resistance to corrosion. Aluminum combined with various percentages of other metals forms alloys which are used in aircraft construction.

Aluminum alloys in which the principal alloying ingredients are manganese, chromium, or magnesium and silicon show little attack in corrosive environments. Alloys in which substantial percentages of copper are used are more susceptible to corrosive action. The total percentage of alloying elements is seldom more than 6 or 7 percent in the wrought alloys.

Aluminum is one of the most widely used metals in modern aircraft construction. It is vital to the aviation industry because of its high strength to weight ratio and its comparative ease of fabrication. The outstanding characteristic of aluminum is its light weight. Aluminum melts at the comparatively low temperature of 1,250 °F. It is nonmagnetic and is an excellent conductor.

Commercially pure aluminum has a tensile strength of about 13,000 psi, but its strength may be approximately doubled by rolling or other cold working processes. By alloying with other metals, or by using heat-treating processes, the tensile strength may be raised to as high as 65,000 psi or to within the strength range of structural steel.

Aluminum alloys, although strong, are easily worked because they are malleable and ductile. They may be rolled into sheets as thin as 0.0017 inch or drawn into wire 0.004 inch in diameter. Most aluminum alloy sheet stock used in aircraft construction range from 0.016 to 0.096 inch in thickness; however, some of the larger aircraft use sheet stock which may be as thick as 0.356 inch.

The various types of aluminum may be divided into two general classes: (1) casting alloys (those suitable for casting in sand, permanent mold, or die castings) and (2) wrought alloys (those which may be shaped by rolling, drawing, or forging). Of these two, the wrought alloys are the most widely used in aircraft construction, being used for stringers, bulkheads, skin, rivets, and extruded sections.

Aluminum casting alloys are divided into two basic groups. In one, the physical properties of the alloys

are determined by the alloying elements and cannot be changed after the metal is cast. In the other, the alloying elements make it possible to heat treat the casting to produce the desired physical properties.

The casting alloys are identified by a letter preceding the alloy number. When a letter precedes a number, it indicates a slight variation in the composition of the original alloy. This variation in composition is simply to impart some desirable quality. In casting alloy 214, for example, the addition of zinc to improve its pouring qualities is indicated by the letter A in front of the number, thus creating the designation A214.

When castings have been heat treated, the heat treatment and the composition of the casting is indicated by the letter T, followed by an alloying number. An example of this is the sand casting alloy 355, which has several different compositions and tempers and is designated by 355-T6, 355-T51, or C355-T51.

Aluminum alloy castings are produced by one of three basic methods: (1) sand mold, (2) permanent mold, or (3) die cast. In casting aluminum, it must be remembered that in most cases different types of alloys must be used for different types of castings. Sand castings and die castings require different types of alloys than those used in permanent molds.

Sand and permanent mold castings are parts produced by pouring molten metal into a previously prepared mold, allowing the metal to solidify or freeze, and then removing the part. If the mold is made of sand, the part is a sand casting; if it is a metallic mold (usually cast iron) the part is a permanent mold casting. Sand and permanent castings are produced by pouring liquid metal into the mold, the metal flowing under the force of gravity alone.

The two principal types of sand casting alloys are 112 and 212. Little difference exists between the two metals from a mechanical properties standpoint, since both are adaptable to a wide range of products.

The permanent mold process is a later development of the sand casting process, the major difference being in the material from which the molds are made. The advantage of this process is that there are fewer openings (called porosity) than in sand castings. The sand and the binder, which is mixed with the sand to hold it together, give off a certain amount of gas which causes porosity in a sand casting.

Permanent mold castings are used to obtain higher mechanical properties, better surfaces, or more accu-

rate dimensions. There are two specific types of permanent mold castings: (1) permanent metal mold with metal cores, and (2) semipermanent types containing sand cores. Because finer grain structure is produced in alloys subjected to the rapid cooling of metal molds, they are far superior to the sand type castings. Alloys 122, A132, and 142 are commonly used in permanent mold castings, the principal uses of which are in internal combustion engines.

Die castings used in aircraft are usually aluminum or magnesium alloy. If weight is of primary importance, magnesium alloy is used because it is lighter than aluminum alloy. However, aluminum alloy is frequently used because it is stronger than most magnesium alloys.

A die casting is produced by forcing molten metal under pressure into a metallic die and allowing it to solidify; then the die is opened and the part removed. The basic difference between permanent mold casting and die casting is that in the permanent mold process the metal flows into the die under gravity. In the die casting operation, the metal is forced under great pressure.

Die castings are used where relatively large production of a given part is involved. Remember, any shape which can be forged can be cast.

Wrought aluminum and wrought aluminum alloys are divided into two general classes: non-heat-treatable alloys and heat-treatable alloys.

Non-heat-treatable alloys are those in which the mechanical properties are determined by the amount of cold work introduced after the final annealing operation. The mechanical properties obtained by cold working are destroyed by any subsequent heating and cannot be restored except by additional cold working, which is not always possible. The “full hard” temper is produced by the maximum amount of cold work that is commercially practicable. Metal in the “as fabricated” condition is produced from the ingot without any subsequent controlled amount of cold working or thermal treatment. There is, consequently, a variable amount of strain hardening, depending upon the thickness of the section.

For heat-treatable aluminum alloys, the mechanical properties are obtained by heat treating to a suitable temperature, holding at that temperature long enough to allow the alloying constituent to enter into solid solution, and then quenching to hold the constituent in solution. The metal is left in a supersaturated, unstable state and is then age hardened either by natural aging

at room temperature or by artificial aging at some elevated temperature.

Wrought Aluminum

Wrought aluminum and wrought aluminum alloys are designated by a four digit index system. The system is broken into three distinct groups: 1xxx group, 2xxx through 8xxx group, and 9xxx group (which is currently unused).

The first digit of a designation identifies the alloy type. The second digit indicates specific alloy modifications. Should the second number be zero, it would indicate no special control over individual impurities. Digits 1 through 9, however, when assigned consecutively as needed for the second number in this group, indicate the number of controls over individual impurities in the metal.

The last two digits of the 1xxx group are used to indicate the hundredths of 1 percent above the original 99 percent designated by the first digit. Thus, if the last two digits were 30, the alloy would contain 99 percent plus 0.30 percent of pure aluminum, or a total of 99.30 percent pure aluminum. Examples of alloys in this group are:

- 1100—99.00 percent pure aluminum with one control over individual impurities.
- 1130—99.30 percent pure aluminum with one control over individual impurities.
- 1275—99.75 percent pure aluminum with two controls over individual impurities.

In the 2xxx through 8xxx groups, the first digit indicates the major alloying element used in the formation of the alloy as follows:

- 2xxx—copper
- 3xxx—manganese
- 4xxx—silicon
- 5xxx—magnesium
- 6xxx—magnesium and silicon
- 7xxx—zinc
- 8xxx—other elements

In the 2xxx through 8xxx alloy groups, the second digit in the alloy designation indicates alloy modifications. If the second digit is zero, it indicates the original alloy, while digits 1 through 9 indicate alloy modifications.

The last two of the four digits in the designation identify the different alloys in the group. [Figure 5-4]

Alloy	Percentage of alloying elements (aluminum and normal impurities constitute remainder)									
	Cobre	Silicone	Manganes	Magnesio	Zinco	Niquel	hromium		Lead	Bismuth
1100	—	—	—	—	—	—	—	—	—	—
3003	—	—	1.2	—	—	—	—	—	—	—
2011	5.5	—	—	—	—	—	—	0.5	0.5	—
2014	4.4	0.8	0.8	0.4	—	—	—	—	—	—
2017	4.0	—	0.5	0.5	—	—	—	—	—	—
2117	2.5	—	—	0.3	—	—	—	—	—	—
2018	4.0	—	—	0.5	—	2.0	—	—	—	—
2024	4.5	—	0.6	1.5	—	—	—	—	—	—
2025	4.5	0.8	0.8	—	—	—	—	—	—	—
4032	0.9	12.5	—	1.0	—	0.9	—	—	—	—
6151	—	1.0	—	0.6	—	—	0.25	—	—	—
5052	—	—	—	2.5	—	—	0.25	—	—	—
6053	—	0.7	—	1.3	—	—	0.25	—	—	—
6061	0.25	0.6	—	1.0	—	—	0.25	—	—	—
7075	1.6	—	—	2.5	5.6	—	0.3	—	—	—

Figure 5-4. Nominal composition of wrought aluminum alloys.

Effect of Alloying Element

1000 series. 99 percent aluminum or higher, excellent corrosion resistance, high thermal and electrical conductivity, low mechanical properties, excellent workability. Iron and silicon are major impurities.

2000 series. Copper is the principal alloying element. Solution heat treatment, optimum properties equal to mild steel, poor corrosion resistance unclad. It is usually clad with 6000 or high purity alloy. Its best known alloy is 2024.

3000 series. Manganese is the principal alloying element of this group which is generally non-heat treatable. The percentage of manganese which will be alloy effective is 1.5 percent. The most popular is 3003, which is of moderate strength and has good working characteristics.

4000 series. Silicon is the principal alloying element of this group, and lowers melting temperature. Its primary use is in welding and brazing. When used in welding heat-treatable alloys, this group will respond to a limited amount of heat treatment.

5000 series. Magnesium is the principal alloying element. It has good welding and corrosion resistant characteristics. High temperatures (over 150°F) or excessive cold working will increase susceptibility to corrosion.

6000 series. Silicon and magnesium form magnesium silicide which makes alloys heat treatable. It is of medium strength, good forming qualities, and has corrosion resistant characteristics.

7000 series. Zinc is the principal alloying element. The most popular alloy of the series is 6061. When coupled with magnesium, it results in heat-treatable alloys of very high strength. It usually has copper and chromium added. The principal alloy of this group is 7075.

Hardness Identification

Where used, the temper designation follows the alloy designation and is separated from it by a dash: i.e., 7075-T6, 2024-T4, and so forth. The temper designation consists of a letter indicating the basic temper which may be more specifically defined by the addition of one or more digits. These designations are as follows:

- F— as fabricated
- O— annealed, recrystallized (wrought products only)
- H— strain hardened
- H1 (plus one or more digits)— strain hardened only
- H2 (plus one or more digits)— strain hardened and partially annealed
- H3 (plus one or more digits)— strain hardened and stabilized

The digit following the designations H1, H2, and H3 indicates the degree of strain hardening, number 8 representing the ultimate tensile strength equal to that achieved by a cold reduction of approximately 75 percent following a full anneal, 0 representing the annealed state.

Magnesium and Magnesium Alloys

Magnesium, the world's lightest structural metal, is a silvery white material weighing only two-thirds as much as aluminum. Magnesium does not possess sufficient strength in its pure state for structural uses, but when alloyed with zinc, aluminum, and manganese it produces an alloy having the highest strength to weight ratio of any of the commonly used metals.

Magnesium is probably more widely distributed in nature than any other metal. It can be obtained from such ores as dolomite and magnesite, and from sea water, underground brines, and waste solutions of potash. With about 10 million pounds of magnesium in 1 cubic mile of sea water, there is no danger of a dwindling supply.

Some of today's aircraft require in excess of one-half ton of this metal for use in hundreds of vital spots. Some wing panels are fabricated entirely from magnesium alloys, weigh 18 percent less than standard aluminum panels, and have flown hundreds of satisfactory hours. Among the aircraft parts that have been made from magnesium with a substantial savings in weight are nosewheel doors, flap cover skin, aileron cover skin, oil tanks, floorings, fuselage parts, wingtips, engine nacelles, instrument panels, radio masts, hydraulic fluid tanks, oxygen bottle cases, ducts, and seats.

Magnesium alloys possess good casting characteristics. Their properties compare favorably with those of cast aluminum. In forging, hydraulic presses are ordinarily used, although, under certain conditions, forging can be accomplished in mechanical presses or with drop hammers.

Magnesium alloys are subject to such treatments as annealing, quenching, solution heat treatment, aging, and stabilizing. Sheet and plate magnesium are annealed at the rolling mill. The solution heat treatment is used to put as much of the alloying ingredients as possible into solid solution, which results in high tensile strength and maximum ductility. Aging is applied to castings following heat treatment where maximum hardness and yield strength are desired.

Magnesium embodies fire hazards of an unpredictable nature. When in large sections, its high thermal conductivity makes it difficult to ignite and prevents it from burning. It will not burn until the melting point of 1,204 °F is reached. However, magnesium dust and fine chips are ignited easily. Precautions must be taken to avoid this if possible. Should a fire occur, it can be extinguished with an extinguishing powder, such as soapstone or graphite. Water or any standard liquid or foam fire extinguisher cause magnesium to burn more rapidly and can cause explosions.

Magnesium alloys produced in the United States consist of magnesium alloyed with varying proportions of aluminum, manganese, and zinc. These alloys are designated by a letter of the alphabet, with the number 1 indicating high purity and maximum corrosion resistance.

Many of the magnesium alloys manufactured in the United States are produced by the Dow Chemical Company and have been given the trade name of Dowmetal™ alloys. To distinguish between these alloys, each is assigned a letter. Thus, we have Dowmetal J, Dowmetal M, and so forth.

Another manufacturer of magnesium alloys is the American Magnesium Corporation, a subsidiary of the Aluminum Company of America. This company uses an identification system similar to that used for aluminum alloys, with the exception that magnesium alloy numbers are preceded with the letters AM. Thus, AM240C is a cast alloy, and AM240C4 is the same alloy in the heat-treated state. AM3S0 is an annealed wrought alloy, and AM3SRT is the same alloy rolled after heat treatment.

Titanium and Titanium Alloys

Titanium was discovered by an English priest named Gregot. A crude separation of titanium ore was accomplished in 1825. In 1906 a sufficient amount of pure titanium was isolated in metallic form to permit a study. Following this study, in 1932, an extraction process was developed which became the first commercial method for producing titanium. The United States Bureau of Mines began making titanium sponge in 1946, and 4 years later the melting process began.

The use of titanium is widespread. It is used in many commercial enterprises and is in constant demand for such items as pumps, screens, and other tools and fixtures where corrosion attack is prevalent. In aircraft construction and repair, titanium is used for fuselage skins, engine shrouds, firewalls, longerons, frames, fittings, air ducts, and fasteners.

Titanium is used for making compressor disks, spacer rings, compressor blades and vanes, through bolts, turbine housings and liners, and miscellaneous hardware for turbine engines.

Titanium, in appearance, is similar to stainless steel. One quick method used to identify titanium is the spark test. Titanium gives off a brilliant white trace ending in a brilliant white burst. Also, identification can be accomplished by moistening the titanium and using it to draw a line on a piece of glass. This will leave a dark line similar in appearance to a pencil mark.

Titanium falls between aluminum and stainless steel in terms of elasticity, density, and elevated temperature strength. It has a melting point of from 2,730 °F to 3,155 °F, low thermal conductivity, and a low coefficient of expansion. It is light, strong, and resistant to stress corrosion cracking. Titanium is approximately 60 percent heavier than aluminum and about 50 percent lighter than stainless steel.

Because of the high melting point of titanium, high temperature properties are disappointing. The ultimate yield strength of titanium drops rapidly above 800 °F. The absorption of oxygen and nitrogen from the air at temperatures above 1,000 °F makes the metal so brittle on long exposure that it soon becomes worthless. However, titanium does have some merit for short time exposure up to 3,000 °F where strength is not important. Aircraft firewalls demand this requirement.

Titanium is nonmagnetic and has an electrical resistance comparable to that of stainless steel. Some of the base alloys of titanium are quite hard. Heat treating and alloying do not develop the hardness of titanium to the high levels of some of the heat-treated alloys of steel. It was only recently that a heat-treatable titanium alloy was developed. Prior to the development of this alloy, heating and rolling was the only method of forming that could be accomplished. However, it is possible to form the new alloy in the soft condition and heat treat it for hardness.

Iron, molybdenum, and chromium are used to stabilize titanium and produce alloys that will quench harden and age harden. The addition of these metals also adds ductility. The fatigue resistance of titanium is greater than that of aluminum or steel.

Titanium becomes softer as the degree of purity is increased. It is not practical to distinguish between the various grades of commercially pure or unalloyed titanium by chemical analysis; therefore, the grades are determined by mechanical properties.

Titanium Designations

The A-B-C classification of titanium alloys was established to provide a convenient and simple means of describing all titanium alloys. Titanium and titanium alloys possess three basic types of crystals: A (alpha), B (beta), and C (combined alpha and beta). Their characteristics are:

- A (alpha)—all around performance; good weldability; tough and strong both cold and hot, and resistant to oxidation.
- B (beta)—bendability; excellent bend ductility; strong both cold and hot, but vulnerable to contamination.
- C (combined alpha and beta for compromise performances)—strong when cold and warm, but weak when hot; good bendability; moderate contamination resistance; excellent forgeability.

Titanium is manufactured for commercial use in two basic compositions: commercially pure titanium and alloyed titanium. A-55 is an example of a commercially pure titanium. It has a yield strength of 55,000 to 80,000 psi and is a general purpose grade for moderate to severe forming. It is sometimes used for nonstructural aircraft parts and for all types of corrosion resistant applications, such as tubing. Type A-70 titanium is closely related to type A-55 but has a yield strength of 70,000 to 95,000 psi. It is used where higher strength is required, and it is specified for many moderately stressed aircraft parts. For many corrosion applications, it is used interchangeably with type A-55. Both type A-55 and type A-70 are weldable.

One of the widely used titanium base alloys is designated as C-110M. It is used for primary structural members and aircraft skin, has 110,000 psi minimum yield strength, and contains 8 percent manganese.

Type A-110AT is a titanium alloy which contains 5 percent aluminum and 2.5 percent tin. It also has a high minimum yield strength at elevated temperatures with the excellent welding characteristics inherent in alpha-type titanium alloys.

Corrosion Characteristics

The corrosion resistance of titanium deserves special mention. The resistance of the metal to corrosion is caused by the formation of a protective surface film of stable oxide or chemi-absorbed oxygen. Film is often produced by the presence of oxygen and oxidizing agents.

Corrosion of titanium is uniform. There is little evidence of pitting or other serious forms of localized attack. Normally, it is not subject to stress corrosion, corrosion fatigue, intergranular corrosion, or galvanic corrosion. Its corrosion resistance is equal or superior to 18-8 stainless steel.

Laboratory tests with acid and saline solutions show titanium polarizes readily. The net effect, in general, is to decrease current flow in galvanic and corrosion cells. Corrosion currents on the surface of titanium and metallic couples are naturally restricted. This partly accounts for good resistance to many chemicals; also, the material may be used with some dissimilar metals with no harmful galvanic effect on either.

Copper and Copper Alloys

Copper is one of the most widely distributed metals. It is the only reddish colored metal and is second only to silver in electrical conductivity. Its use as a structural material is limited because of its great weight. However, some of its outstanding characteristics, such as its high electrical and heat conductivity, in many cases overbalance the weight factor.

Because it is very malleable and ductile, copper is ideal for making wire. It is corroded by salt water but is not affected by fresh water. The ultimate tensile strength of copper varies greatly. For cast copper, the tensile strength is about 25,000 psi, and when cold rolled or cold drawn its tensile strength increases to a range of 40,000 to 67,000 psi.

In aircraft, copper is used primarily in the electrical system for bus bars, bonding, and as lockwire.

Beryllium copper is one of the most successful of all the copper base alloys. It is a recently developed alloy containing about 97 percent copper, 2 percent beryllium, and sufficient nickel to increase the percentage of elongation. The most valuable feature of this metal is that the physical properties can be greatly stepped up by heat treatment, the tensile strength rising from 70,000 psi in the annealed state to 200,000 psi in the heat-treated state. The resistance of beryllium copper to fatigue and wear makes it suitable for diaphragms, precision bearings and bushings, ball cages, and spring washers.

Brass is a copper alloy containing zinc and small amounts of aluminum, iron, lead, manganese, magnesium, nickel, phosphorous, and tin. Brass with a zinc content of 30 to 35 percent is very ductile, but that containing 45 percent has relatively high strength.

Muntz metal is a brass composed of 60 percent copper and 40 percent zinc. It has excellent corrosion resistant qualities in salt water. Its strength can be increased by heat treatment. As cast, this metal has an ultimate tensile strength of 50,000 psi, and it can be elongated 18 percent. It is used in making bolts and nuts, as well as parts that come in contact with salt water.

Red brass, sometimes termed "bronze" because of its tin content, is used in fuel and oil line fittings. This metal has good casting and finishing properties and machines freely.

Bronzes are copper alloys containing tin. The true bronzes have up to 25 percent tin, but those with less than 11 percent are most useful, especially for such items as tube fittings in aircraft.

Among the copper alloys are the copper aluminum alloys, of which the aluminum bronzes rank very high in aircraft usage. They would find greater usefulness in structures if it were not for their strength to weight ratio as compared with alloy steels. Wrought aluminum bronzes are almost as strong and ductile as medium carbon steel, and they possess a high degree of resistance to corrosion by air, salt water, and chemicals. They are readily forged, hot or cold rolled, and many react to heat treatment.

These copper base alloys contain up to 16 percent of aluminum (usually 5 to 11 percent), to which other metals, such as iron, nickel, or manganese, may be added. Aluminum bronzes have good tearing qualities, great strength, hardness, and resistance to both shock and fatigue. Because of these properties, they are used for diaphragms, gears, and pumps. Aluminum bronzes are available in rods, bars, plates, sheets, strips, and forgings.

Cast aluminum bronzes, using about 89 percent copper, 9 percent aluminum, and 2 percent of other elements, have high strength combined with ductility, and are resistant to corrosion, shock, and fatigue. Because of these properties, cast aluminum bronze is used in bearings and pump parts. These alloys are useful in areas exposed to salt water and corrosive gases.

Manganese bronze is an exceptionally high strength, tough, corrosion resistant copper zinc alloy containing aluminum, manganese, iron and, occasionally, nickel or tin. This metal can be formed, extruded, drawn, or rolled to any desired shape. In rod form, it is generally used for machined parts, for aircraft landing gears and brackets.

Silicon bronze is a more recent development composed of about 95 percent copper, 3 percent silicon, and 2 percent manganese, zinc, iron, tin, and aluminum. Although not a bronze in the true sense because of its small tin content, silicon bronze has high strength and great corrosion resistance.

Monel

Monel, the leading high nickel alloy, combines the properties of high strength and excellent corrosion resistance. This metal consists of 68 percent nickel, 29 percent copper, 0.2 percent iron, 1 percent manganese, and 1.8 percent of other elements. It cannot be hardened by heat treatment.

Monel, adaptable to casting and hot or cold working, can be successfully welded. It has working properties similar to those of steel. When forged and annealed, it has a tensile strength of 80,000 psi. This can be increased by cold working to 125,000 psi, sufficient for classification among the tough alloys.

Monel has been successfully used for gears and chains to operate retractable landing gears, and for structural parts subject to corrosion. In aircraft, Monel is used for parts demanding both strength and high resistance to corrosion, such as exhaust manifolds and carburetor needle valves and sleeves.

K-Monel

K-Monel is a nonferrous alloy containing mainly nickel, copper, and aluminum. It is produced by adding a small amount of aluminum to the Monel formula. It is corrosion resistant and capable of being hardened by heat treatment.

K-Monel has been successfully used for gears, and structural members in aircraft which are subjected to corrosive attacks. This alloy is nonmagnetic at all temperatures. K-Monel sheet has been successfully welded by both oxyacetylene and electric arc welding.

Nickel and Nickel Alloys

There are basically two nickel alloys used in aircraft. They are Monel and Inconel. Monel contains about 68 percent nickel and 29 percent copper, plus small amounts of iron and manganese. Nickel alloys can be welded or easily machined. Some of the nickel Monel, especially the nickel Monels containing small amounts of aluminum, are heat-treatable to similar tensile strengths of steel. Nickel Monel is used in gears and parts that require high strength and toughness, such as exhaust systems that require high strength and corrosion resistance at elevated temperatures.

Inconel alloys of nickel produce a high strength, high temperature alloy containing approximately 80 percent nickel, 14 percent chromium, and small amounts of iron and other elements. The nickel Inconel alloys are frequently used in turbine engines because of their ability to maintain their strength and corrosion resistance under extremely high temperature conditions.

Inconel and stainless steel are similar in appearance and are frequently found in the same areas of the engine. Sometimes it is important to identify the difference between the metal samples. A common test is to apply one drop of cupric chloride and hydrochloric acid solution to the unknown metal and allow it to remain for 2 minutes. At the end of the soak period, a shiny spot indicates the material is nickel Inconel, and a copper colored spot indicates stainless steel.

Substitution of Aircraft Metals

In selecting substitute metals for the repair and maintenance of aircraft, it is very important to check the appropriate structural repair manual. Aircraft manufacturers design structural members to meet a specific load requirement for a particular aircraft. The methods of repairing these members, apparently similar in construction, will thus vary with different aircraft.

Four requirements must be kept in mind when selecting substitute metals. The first and most important of these is maintaining the original strength of the structure. The other three are: (1) maintaining contour or aerodynamic smoothness, (2) maintaining original weight, if possible, or keeping added weight to a minimum, and (3) maintaining the original corrosion resistant properties of the metal.

Metalworking Processes

There are three methods of metalworking: (1) hot working, (2) cold working, and (3) extruding. The method used will depend on the metal involved and the part required, although in some instances both hot and cold working methods may be used to make a single part.

Hot Working

Almost all steel is hot worked from the ingot into some form from which it is either hot or cold worked to the finished shape. When an ingot is stripped from its mold, its surface is solid, but the interior is still molten. The ingot is then placed in a soaking pit which retards loss of heat, and the molten interior gradually solidifies. After soaking, the temperature is equalized throughout the ingot, then it is reduced to intermediate size by rolling, making it more readily handled.

The rolled shape is called a bloom when its section dimensions are 6 inches \times 6 inches or larger and approximately square. The section is called a billet when it is approximately square and less than 6 inches \times 6 inches. Rectangular sections which have a width greater than twice their thickness are called slabs. The slab is the intermediate shape from which sheets are rolled.

Blooms, billets, or slabs are heated above the critical range and rolled into a variety of shapes of uniform cross section. Common rolled shapes are sheet, bar, channel, angle, and I-beam. As discussed later in this chapter, hot rolled material is frequently finished by cold rolling or drawing to obtain accurate finish dimensions and a bright, smooth surface.

Complicated sections which cannot be rolled, or sections of which only a small quantity is required, are usually forged. Forging of steel is a mechanical working at temperatures above the critical range to shape the metal as desired. Forging is done either by pressing or hammering the heated steel until the desired shape is obtained.

Pressing is used when the parts to be forged are large and heavy; this process also replaces hammering where high grade steel is required. Since a press is slow acting, its force is uniformly transmitted to the center of the section, thus affecting the interior grain structure as well as the exterior to give the best possible structure throughout.

Hammering can be used only on relatively small pieces. Since hammering transmits its force almost instantly, its effect is limited to a small depth. Thus, it is necessary to use a very heavy hammer or to subject the part to repeated blows to ensure complete working of the section. If the force applied is too weak to reach the center, the finished forged surface will be concave. If the center was properly worked, the surface will be convex or bulged. The advantage of hammering is that the operator has control over both the amount of pressure applied and the finishing temperature, and is able to produce small parts of the highest grade. This type of forging is usually referred to as smith forging. It is used extensively where only a small number of parts are needed. Considerable machining time and material are saved when a part is smith forged to approximately the finished shape.

Steel is often harder than necessary and too brittle for most practical uses when put under severe internal strain. To relieve such strain and reduce brittleness, it is tempered after being hardened. This consists of heating

the steel in a furnace to a specified temperature and then cooling it in air, oil, water, or a special solution. Temper condition refers to the condition of metal or metal alloys with respect to hardness or toughness. Rolling, hammering, or bending these alloys, or heat treating and aging them, causes them to become tougher and harder. At times these alloys become too hard for forming and have to be re-heat treated or annealed.

Metals are annealed to relieve internal stresses, soften the metal, make it more ductile, and refine the grain structure. Annealing consists of heating the metal to a prescribed temperature, holding it there for a specified length of time, and then cooling the metal back to room temperature. To produce maximum softness, the metal must be cooled very slowly. Some metals must be furnace cooled; others may be cooled in air.

Normalizing applies to iron base metals only. Normalizing consists of heating the part to the proper temperature, holding it at that temperature until it is uniformly heated, and then cooling it in still air. Normalizing is used to relieve stresses in metals.

Strength, weight, and reliability are three factors which determine the requirements to be met by any material used in airframe construction and repair. Airframes must be strong and yet as light weight as possible. There are very definite limits to which increases in strength can be accompanied by increases in weight. An airframe so heavy that it could not support a few hundred pounds of additional weight would be of little use.

All metals, in addition to having a good strength/weight ratio, must be thoroughly reliable, thus minimizing the possibility of dangerous and unexpected failures. In addition to these general properties, the material selected for a definite application must possess specific qualities suitable for the purpose.

The material must possess the strength required by the dimensions, weight, and use. The five basic stresses which metals may be required to withstand are tension, compression, shear, bending, and torsion.

The tensile strength of a material is its resistance to a force which tends to pull it apart. Tensile strength is measured in pounds per square inch (psi) and is calculated by dividing the load in pounds required to pull the material apart by its cross-sectional area in square inches.

The compression strength of a material is its resistance to a crushing force which is the opposite of tensile

strength. Compression strength is also measured in psi. When a piece of metal is cut, the material is subjected, as it comes in contact with the cutting edge, to a force known as shear. Shear is the tendency on the part of parallel members to slide in opposite directions. It is like placing a cord or thread between the blades of a pair of scissors (shears). The shear strength is the shear force in psi at which a material fails. It is the load divided by the shear area.

Bending can be described as the deflection or curving of a member due to forces acting upon it. The bending strength of material is the resistance it offers to deflecting forces. Torsion is a twisting force. Such action would occur in a member fixed at one end and twisted at the other. The torsional strength of material is its resistance to twisting.

The relationship between the strength of a material and its weight per cubic inch, expressed as a ratio, is known as the strength/weight ratio. This ratio forms the basis for comparing the desirability of various materials for use in airframe construction and repair. Neither strength nor weight alone can be used as a means of true comparison. In some applications, such as the skin of monocoque structures, thickness is more important than strength, and, in this instance, the material with the lightest weight for a given thickness or gauge is best. Thickness or bulk is necessary to prevent bucking or damage caused by careless handling.

Corrosion is the eating away or pitting of the surface or the internal structure of metals. Because of the thin sections and the safety factors used in aircraft design and construction, it would be dangerous to select a material possessing poor corrosion resistant characteristics.

Another significant factor to consider in maintenance and repair is the ability of a material to be formed, bent, or machined to required shapes. The hardening of metals by cold working or forming is termed work hardening. If a piece of metal is formed (shaped or bent) while cold, it is said to be cold worked. Practically all the work an aviation mechanic does on metal is cold work. While this is convenient, it causes the metal to become harder and more brittle.

If the metal is cold worked too much, that is, if it is bent back and forth or hammered at the same place too often, it will crack or break. Usually, the more malleable and ductile a metal is, the more cold working it can stand. Any process which involves controlled heating and cooling of metals to develop certain desirable characteristics (such as hardness, softness, ductility, tensile strength, or refined grain structure) is

called heat treatment or heat treating. With steels the term "heat treating" has a broad meaning and includes such processes as annealing, normalizing, hardening, and tempering.

In the heat treatment of aluminum alloys, only two processes are included: (1) the hardening and toughening process, and (2) the softening process. The hardening and toughening process is called heat treating, and the softening process is called annealing. Aircraft metals are subjected to both shock and fatigue (vibrational) stresses. Fatigue occurs in materials which are exposed to frequent reversals of loading or repeatedly applied loads, if the fatigue limit is reached or exceeded. Repeated vibration or bending will ultimately cause a minute crack to occur at the weakest point. As vibration or bending continues, the crack lengthens until the part completely fails. This is termed shock and fatigue failure. Resistance to this condition is known as shock and fatigue resistance. It is essential that materials used for critical parts be resistant to these stresses.

Heat treatment is a series of operations involving the heating and cooling of metals in the solid state. Its purpose is to change a mechanical property or combination of mechanical properties so that the metal will be more useful, serviceable, and safe for a definite purpose. By heat treating, a metal can be made harder, stronger, and more resistant to impact. Heat treating can also make a metal softer and more ductile. No one heat treating operation can produce all of these characteristics. In fact, some properties are often improved at the expense of others. In being hardened, for example, a metal may become brittle.

The various heat-treating processes are similar in that they all involve the heating and cooling of metals. They differ, however, in the temperatures to which the metal is heated, the rate at which it is cooled, and, of course, in the final result.

The most common forms of heat treatment for ferrous metals are hardening, tempering, normalizing, annealing, and casehardening. Most nonferrous metals can be annealed and many of them can be hardened by heat treatment. However, there is only one nonferrous metal, titanium, that can be casehardened, and none can be tempered or normalized.

Internal Structure of Metals

The results obtained by heat treatment depend to a great extent on the structure of the metal and on the manner in which the structure changes when the metal is heated and cooled. A pure metal cannot be hardened

by heat treatment because there is little change in its structure when heated. On the other hand, most alloys respond to heat treatment since their structures change with heating and cooling.

An alloy may be in the form of a solid solution, a mechanical mixture, or a combination of a solid solution and a mechanical mixture. When an alloy is in the form of a solid solution, the elements and compounds which form the alloy are absorbed, one into the other, in much the same way that salt is dissolved in a glass of water, and the constituents cannot be identified even under a microscope.

When two or more elements or compounds are mixed but can be identified by microscopic examination, a mechanical mixture is formed. A mechanical mixture can be compared to the mixture of sand and gravel in concrete. The sand and gravel are both visible. Just as the sand and gravel are held together and kept in place by the matrix of cement, the other constituents of an alloy are embedded in the matrix formed by the base metal.

An alloy in the form of a mechanical mixture at ordinary temperatures may change to a solid solution when heated. When cooled back to normal temperature, the alloy may return to its original structure. On the other hand, it may remain a solid solution or form a combination of a solid solution and mechanical mixture. An alloy which consists of a combination of solid solution and mechanical mixture at normal temperatures may change to a solid solution when heated. When cooled, the alloy may remain a solid solution, return to its original structure, or form a complex solution.

Heat-Treating Equipment

Successful heat treating requires close control over all factors affecting the heating and cooling of metals. Such control is possible only when the proper equipment is available and the equipment is selected to fit the particular job. Thus, the furnace must be of the proper size and type and must be so controlled that temperatures are kept within the limits prescribed for each operation. Even the atmosphere within the furnace affects the condition of the part being heat treated. Further, the quenching equipment and the quenching medium must be selected to fit the metal and the heat-treating operation. Finally, there must be equipment for handling parts and materials, for cleaning metals, and for straightening parts.

Furnaces and Salt Baths

There are many different types and sizes of furnaces used in heat treatment. As a general rule, furnaces are designed to operate in certain specific temperature ranges and attempted use in other ranges frequently results in work of inferior quality.

In addition, using a furnace beyond its rated maximum temperature shortens its life and may necessitate costly and time consuming repairs.

Fuel fired furnaces (gas or oil) require air for proper combustion and an air compressor or blower is therefore necessary. These furnaces are usually of the muffler type; that is, the combustion of the fuel takes place outside of and around the chamber in which the work is placed. If an open muffler is used, the furnace should be designed to prevent the direct impingement of flame on the work.

In furnaces heated by electricity, the heating elements are generally in the form of wire or ribbon. Good design requires incorporation of additional heating elements at locations where maximum heat loss may be expected. Such furnaces commonly operate at up to a maximum temperature of about 2,000 °F. Furnaces operating at temperatures up to about 2,500 °F usually employ resistor bars of sintered carbides.

Temperature Measurement and Control

Temperature in the heat-treating furnace is measured by a thermoelectric instrument known as a pyrometer. This instrument measures the electrical effect of a thermocouple and, hence, the temperature of the metal being treated. A complete pyrometer consists of three parts—a thermocouple, extension leads, and meter.

Furnaces intended primarily for tempering may be heated by gas or electricity and are frequently equipped with a fan for circulating the hot air.

Salt baths are available for operating at either tempering or hardening temperatures. Depending on the composition of the salt bath, heating can be conducted at temperatures as low as 325 °F to as high as 2,450 °F. Lead baths can be used in the temperature range of 650 °F to 1,700 °F. The rate of heating in lead or salt baths is much faster in furnaces.

Heat-treating furnaces differ in size, shape, capacity, construction, operation, and control. They may be circular or rectangular and may rest on pedestals or directly on the floor. There are also pit-type furnaces, which are below the surface of the floor. When metal is

to be heated in a bath of molten salt or lead, the furnace must contain a pot or crucible for the molten bath.

The size and capacity of a heat-treating furnace depends on the intended use. A furnace must be capable of heating rapidly and uniformly, regardless of the desired maximum temperature or the mass of the charge. An oven-type furnace should have a working space (hearth) about twice as long and three times as wide as any part that will be heated in the furnace.

Accurate temperature measurement is essential to good heat treating. The usual method is by means of thermocouples: the most common base metal couples are copper-constantan (up to about 700 °F), iron-constantan (up to about 1,400 °F), and chromel-alumel (up to about 2,200 °F). The most common noble metal couples (which can be used up to about 2,800 °F) are platinum coupled with either the alloy 87 percent platinum (13 percent rhodium) or the alloy 90 percent platinum (10 percent rhodium). The temperatures quoted are for continuous operation.

The life of thermocouples is affected by the maximum temperature (which may frequently exceed those given above) and by the furnace atmosphere. Iron-constantan is more suited for use in reducing and chromel-alumel in oxidizing atmospheres. Thermocouples are usually encased in metallic or ceramic tubes closed at the hot end to protect them from the furnace gases. A necessary attachment is an instrument, such as a millivoltmeter or potentiometer, for measuring the electromotive force generated by the thermocouple. In the interest of accurate control, place the hot junction of the thermocouple as close to the work as possible. The use of an automatic controller is valuable in controlling the temperature at the desired value.

Pyrometers may have meters either of the indicating type or recording type. Indicating pyrometers give direct reading of the furnace temperature. The recording type produces a permanent record of the temperature range throughout the heating operation by means of an inked stylus attached to an arm which traces a line on a sheet of calibrated paper or temperature chart.

Pyrometer installations on all modern furnaces provide automatic regulation of the temperature at any desired setting. Instruments of this type are called controlling potentiometer pyrometers. They include a current regulator and an operating mechanism, such as a relay.

Heating

The object in heating is to transform pearlite (a mixture of alternate strips of ferrite and iron carbide in a single grain) to austenite as the steel is heated through the critical range. Since this transition takes time, a relatively slow rate of heating must be used. Ordinarily, the cold steel is inserted when the temperature in the furnace is from 300 °F to 500 °F below the hardening temperature. In this way, too rapid heating through the critical range is prevented.

If temperature measuring equipment is not available, it becomes necessary to estimate temperatures by some other means. An inexpensive, yet fairly accurate method involves the use of commercial crayons, pellets, or paints that melt at various temperatures within the range of 125 °F to 1,600 °F. The least accurate method of temperature estimation is by observation of the color of the hot hearth of the furnace or of the work. The heat colors observed are affected by many factors, such as the conditions of artificial or natural light, the character of the scale on the work, and so forth. Steel begins to appear dull red at about 1,000 °F, and as the temperature increases, the color changes gradually through various shades of red to orange, to yellow, and finally to white. A rough approximation of the correspondence between color and temperature is indicated in Figure 5-5.

It is also possible to secure some idea of the temperature of a piece of carbon or low alloy steel, in the low temperature range used for tempering, from the color of the thin oxide film that forms on the cleaned surface of the steel when heated in this range. The approximate temperature/color relationship is indicated on the lower portion of the scale in Figure 5-5.

It is often necessary or desirable to protect steel or cast iron from surface oxidation (scaling) and loss of carbon from the surface layers (decarburization). Commercial furnaces, therefore, are generally equipped with some means of atmosphere control. This usually is in the form of a burner for burning controlled amounts of gas and air and directing the products of combustion into the furnace muffle. Water vapor, a product of this combustion, is detrimental and many furnaces are equipped with a means for eliminating it. For furnaces not equipped with atmosphere control, a variety of external atmosphere generators are available. The gas so generated is piped into the furnace and one generator may supply several furnaces. If no method of atmosphere control is available, some degree of protection may be secured by covering the work with cast iron borings or chips.

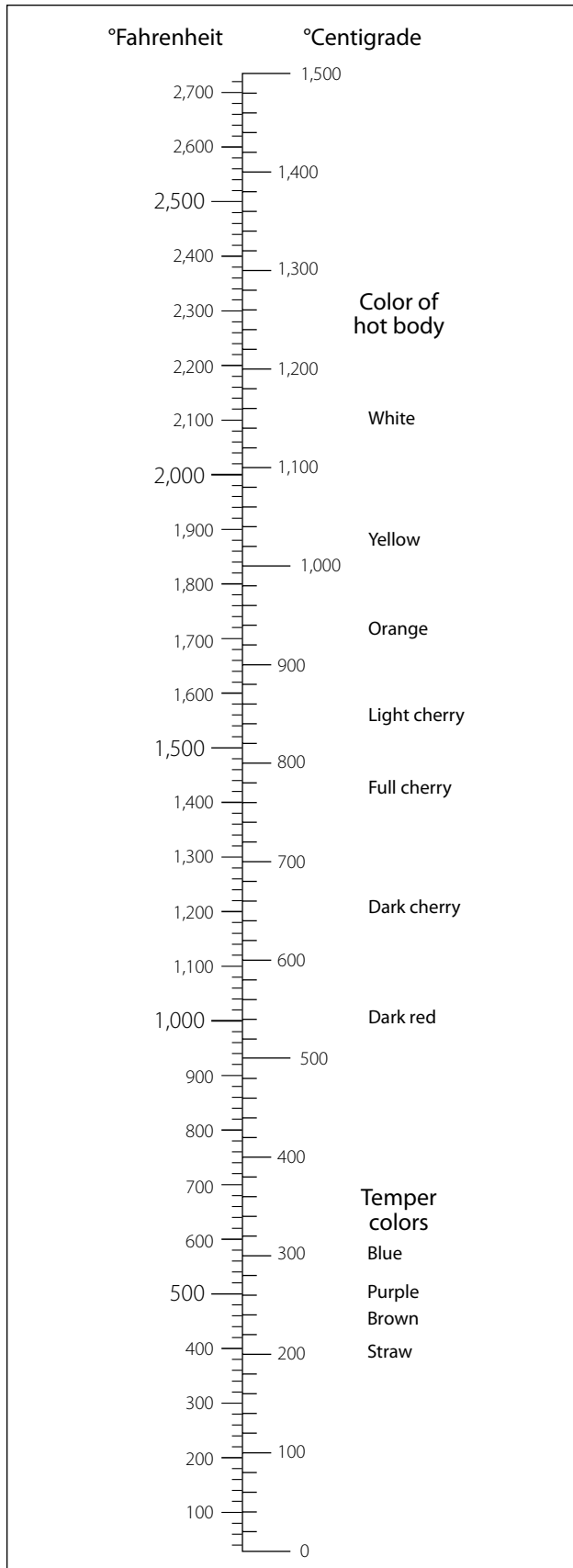

Figure 5-5. Temperature chart indicating conversion of Centigrade to Fahrenheit or visa versa, color temperature scale for hardening temperature range, and tempering temperature range.

Since the work in salt or lead baths is surrounded by the liquid heating medium, the problem of preventing scaling or decarburization is simplified.

Vacuum furnaces also are used for annealing steels, especially when a bright nonoxidized surface is a prime consideration.

Soaking

The temperature of the furnace must be held constant during the soaking period, since it is during this period that rearrangement of the internal structure of the steel takes place. Soaking temperatures for various types of steel are specified in ranges varying as much as 100 °F. [Figure 5-6] Small parts are soaked in the lower part of the specified range and heavy parts in the upper part of the specified range. The length of the soaking period depends upon the type of steel and the size of the part. Naturally, heavier parts require longer soaking to ensure equal heating throughout. As a general rule, a soaking period of 30 minutes to 1 hour is sufficient for the average heat-treating operation.

Cooling

The rate of cooling through the critical range determines the form that the steel will retain. Various rates of cooling are used to produce the desired results. Still air is a slow cooling medium, but is much faster than furnace cooling. Liquids are the fastest cooling media and are therefore used in hardening steels.

There are three commonly used quenching liquids—brine, water, and oil. Brine is the strongest quenching medium, water is next, and oil is the least. Generally, an oil quench is used for alloy steels, and brine or water for carbon steels.

Quenching Media

Quenching solutions act only through their ability to cool the steel. They have no beneficial chemical action on the quenched steel and in themselves impart no unusual properties. Most requirements for quenching media are met satisfactorily by water or aqueous solutions of inorganic salts, such as table salt or caustic soda, or by some type of oil. The rate of cooling is relatively rapid during quenching in brine, somewhat less rapid in water, and slow in oil.

Brine usually is made of a 5 to 10 percent solution of salt (sodium chloride) in water. In addition to its greater cooling speed, brine has the ability to “throw” the scale from steel during quenching. The cooling ability of both water and brine, particularly water, is considerably affected by their temperature. Both

Steel No.	Temperatures			Quenching medium (n)	Tempering (drawing) temperature for tensile strength (psi)				
	Normalizing air cool (°F)	Annealing (°F)	Hardening (°F)		100,000 (°F)	125,000 (°F)	150,000 (°F)	180,000 (°F)	200,000 (°F)
1020	1,650–1,750	1,600–1,700	1,575–1,675	Water	—	—	—	—	—
1022 (x1020)	1,650–1,750	1,600–1,700	1,575–1,675	Water	—	—	—	—	—
1025	1,600–1,700	1,575–1,650	1,575–1,675	Water	(a)	—	—	—	—
1035	1,575–1,650	1,575–1,625	1,525–1,600	Water	875	—	—	—	—
1045	1,550–1,600	1,550–1,600	1,475–1,550	Oil or water	1,150	—	—	(n)	—
1095	1,475–1,550	1,450–1,500	1,425–1,500	Oil	(b)	—	1,100	850	750
2330	1,475–1,525	1,425–1,475	1,450–1,500	Oil or water	1,100	950	800	—	—
3135	1,600–1,650	1,500–1,550	1,475–1,525	Oil	1,250	1,050	900	750	650
3140	1,600–1,650	1,500–1,550	1,475–1,525	Oil	1,325	1,075	925	775	700
4037	1,600	1,525–1,575	1,525–1,575	Oil or water	1,225	1,100	975	—	—
4130 (x4130)	1,600–1,700	1,525–1,575	1,525–1,625	Oil (c)	(d)	1,050	900	700	575
4140	1,600–1,650	1,525–1,575	1,525–1,575	Oil	1,350	1,100	1,025	825	675
4150	1,550–1,600	1,475–1,525	1,550–1,550	Oil	—	1,275	1,175	1,050	950
4340 (x4340)	1,550–1,625	1,525–1,575	1,475–1,550	Oil	—	1,200	1,050	950	850
4640	1,675–1,700	1,525–1,575	1,500–1,550	Oil	—	1,200	1,050	750	625
6135	1,600–1,700	1,550–1,600	1,575–1,625	Oil	1,300	1,075	925	800	750
6150	1,600–1,650	1,525–1,575	1,550–1,625	Oil	(d)(e)	1,200	1,000	900	800
6195	1,600–1,650	1,525–1,575	1,500–1,550	Oil	(f)	—	—	—	—
NE8620	—	—	1,525–1,575	Oil	—	1,000	—	—	—
NE8630	1,650	1,525–1,575	1,525–1,575	Oil	—	1,125	975	775	675
NE8735	1,650	1,525–1,575	1,525–1,575	Oil	—	1,175	1,025	875	775
NE8740	1,625	1,500–1,550	1,500–1,550	Oil	—	1,200	1,075	925	850
30905	—	(g)(h)	(i)	—	—	—	—	—	—
51210	1,525–1,575	1,525–1,575	1,775–1,825 (j)	Oil	1,200	1,100	(k)	750	—
51335	—	1,525–1,575	1,775–1,850	Oil	—	—	—	—	—
52100	1,625–1,700	1,400–1,450	1,525–1,550	Oil	(f)	—	—	—	—
Corrosion resisting (16-2)(1)	—	—	—	—	(m)	—	—	—	—
Silicon Chromium (for springs)	—	—	1,700–1,725	Oil	—	—	—	—	—

Figure 5-6. Heat treatment procedures for steels.

Notes:

- (a) Draw at 1,150°F for tensile strength of 70,000 psi.
- (b) For spring temper draw at 800–900°F. Rockwell hardness C-40–45.
- (c) Bars or forgings may be quenched in water from 1,500–1,600°F.
- (d) Air cooling from the normalizing temperature will produce a tensile strength of approximately 90,000 psi.
- (e) For spring temper draw at 850–950°F. Rockwell hardness C-40–45.
- (f) Draw at 350–450°F to remove quenching strains. Rockwell hardness C-60–65.
- (g) Anneal at 1,600–1,700°F to remove residual stresses due to welding or cold work. May be applied only to steel containing titanium or columbium.
- (h) Anneal at 1,900–2,100°F to produce maximum softness and corrosion resistance. Cool in air or quench in water.
- (i) Harden by cold work only.
- (j) Lower side of range for sheet 0.06 inch and under. Middle of range for sheet and wire 0.125 inch. Upper side of range for forgings.
- (k) Not recommended for intermediate tensile strengths because of low impact.
- (l) AN-QQ-S-770—It is recommended that, prior to tempering, corrosion-resisting (16 Cr-2 Ni) steel be quenched in oil from a temperature of 1,875–1,900°F, after a soaking period of 30 minutes at this temperature. To obtain a tensile strength at 115,000 psi, the tempering temperature should be approximately 525°F. A holding time at these temperatures of about 2 hours is recommended. Tempering temperatures between 700°F and 1,100°F will not be approved.
- (m) Draw at approximately 800°F and cool in air for Rockwell hardness of C-50.
- (n) Water used for quenching shall be within the temperature range of 80–150°F.

Figure 5-6. Heat-treatment procedures for steels. (continued)

should be kept cold—well below 60 °F. If the volume of steel being quenched tends to raise the temperature of the bath appreciably, add ice or use some means of refrigeration to cool the quenching bath.

There are many specially prepared quenching oils on the market; their cooling rates do not vary widely. A straight mineral oil with a Saybolt viscosity of about 100 at 100 °F is generally used. Unlike brine and water, the oils have the greatest cooling velocity at a slightly elevated temperature—about 100–140 °F—because of their decreased viscosity at these temperatures.

When steel is quenched, the liquid in immediate contact with the hot surface vaporizes; this vapor reduces the rate of heat abstraction markedly. Vigorous agitation of the steel or the use of a pressure spray quench is necessary to dislodge these vapor films and thus permit the desired rate of cooling.

The tendency of steel to warp and crack during the quenching process is difficult to overcome because certain parts of the article cool more rapidly than others. The following recommendations will greatly reduce the warping tendency.

1. Never throw a part into the quenching bath. By permitting it to lie on the bottom of the bath, it is apt to cool faster on the top side than on the bottom side, thus causing it to warp or crack.
2. Agitate the part slightly to destroy the coating of vapor that could prevent it from cooling evenly and rapidly. This allows the bath to dissipate its heat to the atmosphere.
3. Immerse irregular shaped parts so that the heavy end enters the bath first.

Quenching Equipment

The quenching tank should be of the proper size to handle the material being quenched. Use circulating pumps and coolers to maintain approximately constant temperatures when doing a large amount of quenching. To avoid building up a high concentration of salt in the quenching tank, make provisions for adding fresh water to the quench tank used for molten salt baths.

Tank location in reference to the heat-treating furnace is very important. Situate the tank to permit rapid transfer of the part from the furnace to the quenching medium. A delay of more than a few seconds will, in many instances, prove detrimental to the effectiveness of the heat treatment. When heat treating material of thin section, employ guard sheets to retard the loss of heat during transfer to the quench tank. Provide a rinse tank to remove all salt from the material after quenching if the salt is not adequately removed in the quenching tank.

Heat Treatment of Ferrous Metals

The first important consideration in the heat treatment of a steel part is to know its chemical composition. This, in turn, determines its upper critical point. When the upper critical point is known, the next consideration is the rate of heating and cooling to be used. Carrying out these operations involves the use of uniform heating furnaces, proper temperature controls, and suitable quenching mediums.

Behavior of Steel During Heating and Cooling

Changing the internal structure of a ferrous metal is accomplished by heating to a temperature above its upper critical point, holding it at that temperature for a time sufficient to permit certain internal changes to

occur, and then cooling to atmospheric temperature under predetermined, controlled conditions.

At ordinary temperatures, the carbon in steel exists in the form of particles of iron carbide scattered throughout an iron matrix known as “ferrite.” The number, size, and distribution of these particles determine the hardness of the steel. At elevated temperatures, the carbon is dissolved in the iron matrix in the form of a solid solution called “austenite,” and the carbide particles appear only after the steel has been cooled. If the cooling is slow, the carbide particles are relatively coarse and few. In this condition, the steel is soft. If the cooling is rapid, as by quenching in oil or water, the carbon precipitates as a cloud of very fine carbide particles, and the steel is hard. The fact that the carbide particles can be dissolved in austenite is the basis of the heat treatment of steel. The temperatures at which this transformation takes place are called the critical points and vary with the composition of the steel. The percentage of carbon in the steel has the greatest influence on the critical points of heat treatment.

Hardening

Pure iron, wrought iron, and extremely low carbon steels cannot be appreciably hardened by heat treatment, since they contain no hardening element. Cast iron can be hardened, but its heat treatment is limited. When cast iron is cooled rapidly, it forms white iron, which is hard and brittle. When cooled slowly, it forms gray iron, which is soft but brittle under impact.

In plain carbon steel, the maximum hardness depends almost entirely on the carbon content of the steel. As the carbon content increases, the ability of the steel to be hardened increases. However, this increase in the ability to harden with an increase in carbon content continues only to a certain point. In practice, that point is 0.85 percent carbon content. When the carbon content is increased beyond 0.85 percent, there is no increase in wear resistance.

For most steels, the hardening treatment consists of heating the steel to a temperature just above the upper critical point, soaking or holding for the required length of time, and then cooling it rapidly by plunging the hot steel into oil, water, or brine. Although most steels must be cooled rapidly for hardening, a few may be cooled in still air. Hardening increases the hardness and strength of the steel but makes it less ductile.

When hardening carbon steel, it must be cooled to below 1,000 °F in less than 1 second. Should the time required for the temperature to drop to 1,000 °F exceed

1 second, the austenite begins to transform into fine pearlite. This pearlite varies in hardness, but is much harder than the pearlite formed by annealing and much softer than the martensite desired. After the 1,000 °F temperature is reached, the rapid cooling must continue if the final structure is to be all martensite.

When alloys are added to steel, the time limit for the temperature drop to 1,000 °F increases above the 1 second limit for carbon steels. Therefore, a slower quenching medium will produce hardness in alloy steels.

Because of the high internal stresses in the “as quenched” condition, steel must be tempered just before it becomes cold. The part should be removed from the quenching bath at a temperature of approximately 200 °F, since the temperature range from 200 °F down to room temperature is the cracking range.

Hardening temperatures and quenching mediums for the various types of steel are listed in Figure 5-6.

Hardening Precautions

A variety of different shapes and sizes of tongs for handling hot steels is necessary. It should be remembered that cooling of the area contacted by the tongs is retarded and that such areas may not harden, particularly if the steel being treated is very shallow hardening. Small parts may be wired together or quenched in baskets made of wire mesh.

Special quenching jigs and fixtures are frequently used to hold steels during quenching in a manner to restrain distortion.

When selective hardening is desired, portions of the steel may be protected by covering with alundum cement or some other insulating material. Selective hardening may be accomplished also by the use of water or oil jets designed to direct quenching medium on the areas to be hardened. This also is accomplished by the induction and flame hardening procedures previously described, particularly on large production jobs.

Shallow hardening steels, such as plain carbon and certain varieties of alloy steels, have such a high critical cooling rate that they must be quenched in brine or water to effect hardening. In general, intricately shaped sections should not be made of shallow hardening steels because of the tendency of these steels to warp and crack during hardening. Such items should be made of deeper hardening steels capable of being hardened by quenching in oil or air.

Tempering

Tempering reduces the brittleness imparted by hardening and produces definite physical properties within the steel. Tempering always follows, never precedes, the hardening operation. In addition to reducing brittleness, tempering softens the steel.

Tempering is always conducted at temperatures below the low critical point of the steel. In this respect, tempering differs from annealing, normalizing, or hardening, all of which require temperatures above the upper critical point. When hardened steel is reheated, tempering begins at 212 °F and continues as the temperature increases toward the low critical point. By selecting a definite tempering temperature, the resulting hardness and strength can be predetermined. Approximate temperatures for various tensile strengths are listed in Figure 5-6. The minimum time at the tempering temperature should be 1 hour. If the part is over 1 inch in thickness, increase the time by 1 hour for each additional inch of thickness. Tempered steels used in aircraft work have from 125,000 to 200,000 psi ultimate tensile strength.

Generally, the rate of cooling from the tempering temperature has no effect on the resulting structure; therefore, the steel is usually cooled in still air after being removed from the furnace.

Annealing

Annealing of steel produces a fine grained, soft, ductile metal without internal stresses or strains. In the annealed state, steel has its lowest strength. In general, annealing is the opposite of hardening.

Annealing of steel is accomplished by heating the metal to just above the upper critical point, soaking at that temperature, and cooling very slowly in the furnace. (Refer to Figure 5-6 for recommended temperatures.) Soaking time is approximately 1 hour per inch of thickness of the material. To produce maximum softness in steel, the metal must be cooled very slowly. Slow cooling is obtained by shutting off the heat and allowing the furnace and metal to cool together to 900 °F or lower, then removing the metal from the furnace and cooling in still air. Another method is to bury the heated steel in ashes, sand, or other substance that does not conduct heat readily.

Normalizing

The normalizing of steel removes the internal stresses set up by heat treating, welding, casting, forming, or machining. Stress, if not controlled, will lead to failure.

Because of the better physical properties, aircraft steels are often used in the normalized state, but seldom, if ever, in the annealed state.

One of the most important uses of normalizing in aircraft work is in welded parts. Welding causes strains to be set up in the adjacent material. In addition, the weld itself is a cast structure as opposed to the wrought structure of the rest of the material. These two types of structures have different grain sizes, and to refine the grain as well as to relieve the internal stresses, all welded parts should be normalized after fabrication.

Normalizing is accomplished by heating the steel above the upper critical point and cooling in still air. The more rapid quenching obtained by air cooling, as compared to furnace cooling, results in a harder and stronger material than that obtained by annealing. Recommended normalizing temperatures for the various types of aircraft steels are listed in Figure 5-6.

Casehardening

Casehardening produces a hard wear-resistant surface or case over a strong, tough core. Casehardening is ideal for parts which require a wear-resistant surface and, at the same time, must be tough enough internally to withstand the applied loads. The steels best suited to casehardening are the low carbon and low alloy steels. If high carbon steel is casehardened, the hardness penetrates the core and causes brittleness. In casehardening, the surface of the metal is changed chemically by introducing a high carbide or nitride content. The core is unaffected chemically.

When heat treated, the surface responds to hardening while the core toughens. The common forms of casehardening are *carburizing*, *cyaniding*, and *nitriding*. Since cyaniding is not used in aircraft work, only carburizing and nitriding are discussed in this section.

Carburizing

Carburizing is a casehardening process in which carbon is added to the surface of low carbon steel. Thus, a carburized steel has a high carbon surface and a low carbon interior. When the carburized steel is heat treated, the case is hardened while the core remains soft and tough.

A common method of carburizing is called “pack carburizing.” When carburizing is to be done by this method, the steel parts are packed in a container with charcoal or some other material rich in carbon. The container is then sealed with fire clay, placed in a furnace, heated to approximately 1,700 °F, and soaked at

that temperature for several hours. As the temperature increases, carbon monoxide gas forms inside the container and, being unable to escape, combines with the gamma iron in the surface of the steel. The depth to which the carbon penetrates depends on the length of the soaking period. For example, when carbon steel is soaked for 8 hours, the carbon penetrates to a depth of about 0.062 inch.

In another method of carburizing, called “gas carburizing,” a material rich in carbon is introduced into the furnace atmosphere. The carburizing atmosphere is produced by the use of various gases or by the burning of oil, wood, or other materials. When the steel parts are heated in this atmosphere, carbon monoxide combines with the gamma iron to produce practically the same results as those described under the pack carburizing process.

A third method of carburizing is that of “liquid carburizing.” In this method, the steel is placed in a molten salt bath that contains the chemicals required to produce a case comparable with one resulting from pack or gas carburizing.

Alloy steels with low carbon content as well as low carbon steels may be carburized by any of the three processes. However, some alloys, such as nickel, tend to retard the absorption of carbon. As a result, the time required to produce a given thickness of case varies with the composition of the metal.

Nitriding

Nitriding is unlike other casehardening processes in that, before nitriding, the part is heat treated to produce definite physical properties. Thus, parts are hardened and tempered before being nitrided. Most steels can be nitrided, but special alloys are required for best results. These special alloys contain aluminum as one of the alloying elements and are called “nitralloys.”

In nitriding, the part is placed in a special nitriding furnace and heated to a temperature of approximately 1,000 °F. With the part at this temperature, ammonia gas is circulated within the specially constructed furnace chamber. The high temperature cracks the ammonia gas into nitrogen and hydrogen. The ammonia which does not break down is caught in a water trap below the regions of the other two gases. The nitrogen reacts with the iron to form nitride. The iron nitride is dispersed in minute particles at the surface and works inward. The depth of penetration depends on the length of the treatment. In nitriding, soaking periods as long as 72

hours are frequently required to produce the desired thickness of case.

Nitriding can be accomplished with a minimum of distortion, because of the low temperature at which parts are casehardened and because no quenching is required after exposure to the ammonia gas.

Heat Treatment of Nonferrous Metals

Aluminum Alloys

In the wrought form, commercially pure aluminum is known as 1100. It has a high degree of resistance to corrosion and is easily formed into intricate shapes. It is relatively low in strength and does not have the properties required for structural aircraft parts. High strengths are generally obtained by the process of alloying. The resulting alloys are less easily formed and, with some exceptions, have lower resistance to corrosion than 1100 aluminum.

Alloying is not the only method of increasing the strength of aluminum. Like other materials, aluminum becomes stronger and harder as it is rolled, formed, or otherwise cold worked. Since the hardness depends on the amount of cold working done, 1100 and some wrought aluminum alloys are available in several strain hardened tempers. The soft or annealed condition is designated O. If the material is strain hardened, it is said to be in the H condition.

The most widely used alloys in aircraft construction are hardened by heat treatment rather than by cold work. These alloys are designated by a somewhat different set of symbols: T4 and W indicate solution heat treated and quenched but not aged, and T6 indicates an alloy in the heat treated hardened condition.

- W—Solution heat treated, unstable temper
- T—Treated to produce stable tempers other than F, O, or H
- T2—Annealed (cast products only)
- T3—Solution heat treated and then cold worked
- T4—Solution heat treated
- T5—Artificially aged only
- T6—Solution heat treated and then artificially aged
- T7—Solution heat treated and then stabilized
- T8—Solution heat treated, cold worked, and then artificially aged

- T9—Solution heat treated, artificially aged, and then cold worked
- T10—Artificially aged and then cold worked

Additional digits may be added to T1 through T10 to indicate a variation in treatment which significantly alters the characteristics of the product.

Aluminum alloy sheets are marked with the specification number on approximately every square foot of material. If for any reason this identification is not on the material, it is possible to separate the heat-treatable alloys from the non-heat-treatable alloys by immersing a sample of the material in a 10 percent solution of caustic soda (sodium hydroxide). The heat-treatable alloys will turn black due to the copper content, whereas the others will remain bright. In the case of clad material, the surface will remain bright, but there will be a dark area in the middle when viewed from the edge.

Alclad Aluminum

The terms “Alclad and Pureclad” are used to designate sheets that consist of an aluminum alloy core coated with a layer of pure aluminum to a depth of approximately 5 1/2 percent on each side. The pure aluminum coating affords a dual protection for the core, preventing contact with any corrosive agents, and protecting the core electrolytically by preventing any attack caused by scratching or from other abrasions.

There are two types of heat treatments applicable to aluminum alloys. One is called solution heat treatment, and the other is known as precipitation heat treatment. Some alloys, such as 2017 and 2024, develop their full properties as a result of solution heat treatment followed by about 4 days of aging at room temperature. Other alloys, such as 2014 and 7075, require both heat treatments.

The alloys that require precipitation heat treatment (artificial aging) to develop their full strength also age to a limited extent at room temperature; the rate and amount of strengthening depends upon the alloy. Some reach their maximum natural or room temperature aging strength in a few days, and are designated as -T4 or -T3 temper. Others continue to age appreciably over a long period of time.

Because of this natural aging, the -W designation is specified only when the period of aging is indicated, for example, 7075-W (1/2 hour). Thus, there is considerable difference in the mechanical and physical properties

of freshly quenched (-W) material and material that is in the -T3 or -T4 temper.

The hardening of an aluminum alloy by heat treatment consists of four distinct steps:

1. Heating to a predetermined temperature.
2. Soaking at temperature for a specified length of time.
3. Rapidly quenching to a relatively low temperature.
4. Aging or precipitation hardening either spontaneously at room temperature, or as a result of a low temperature thermal treatment.

The first three steps above are known as solution heat treatment, although it has become common practice to use the shorter term, “heat treatment.” Room temperature hardening is known as natural aging, while hardening done at moderate temperatures is called artificial aging, or precipitation heat treatment.

Solution Heat Treatment

Temperature

The temperatures used for solution heat treating vary with different alloys and range from 825 °F to 980 °F. As a rule, they must be controlled within a very narrow range (± 10 °F) to obtain specified properties.

If the temperature is too low, maximum strength will not be obtained. When excessive temperatures are used, there is danger of melting the low melting constituents of some alloys with consequent lowering of the physical properties of the alloy. Even if melting does not occur, the use of higher than recommended temperatures promotes discoloration and increases quenching strains.

Time at Temperature

The time at temperature, referred to as soaking time, is measured from the time the coldest metal reaches the minimum limit of the desired temperature range. The soaking time varies, depending upon the alloy and thickness, from 10 minutes for thin sheets to approximately 12 hours for heavy forgings. For the heavy sections, the nominal soaking time is approximately 1 hour for each inch of cross-sectional thickness. [Figure 5-7]

Choose the minimum soaking time necessary to develop the required physical properties. The effect of an abbreviated soaking time is obvious. An excessive soaking period aggravates high temperature oxidation. With clad material, prolonged heating results in exces-

Thickness (inch)	Time (minutes)
Up to .032	30
.032 to 1/8	30
1/8 to 1/4	40
Over 1/4	60

Note: Soaking time starts when the metal (or the molten bath) reaches a temperature within the range specified above.

Figure 5-7. Typical soaking times for heat treatment.

sive diffusion of copper and other soluble constituents into the protective cladding and may defeat the purpose of cladding.

Quenching

After the soluble constituents are in solid solution, the material is quenched to prevent or retard immediate reprecipitation. Three distinct quenching methods are employed. The one to be used in any particular instance depends upon the part, the alloy, and the properties desired.

Cold Water Quenching

Parts produced from sheet, extrusions, tubing, small forgings, and similar type material are generally quenched in a cold water bath. The temperature of the water before quenching should not exceed 85 °F.

Using a sufficient quantity of water keeps the temperature rise under 20 °F. Such a drastic quench ensures maximum resistance to corrosion. This is particularly important when working with such alloys as 2017, 2024, and 7075. This is the reason a drastic quench is preferred, even though a slower quench may produce the required mechanical properties.

Hot Water Quenching

Large forgings and heavy sections can be quenched in hot or boiling water. This type of quench minimizes distortion and alleviates cracking which may be produced by the unequal temperatures obtained during the quench. The use of a hot water quench is permitted with these parts because the temperature of the quench water does not critically affect the resistance to corrosion of the forging alloys. In addition, the resistance to corrosion of heavy sections is not as critical a factor as for thin sections.

Spray Quenching

High velocity water sprays are useful for parts formed from clad sheet and for large sections of almost all alloys. This type of quench also minimizes distortion

and alleviates quench cracking. However, many specifications forbid the use of spray quenching for bare 2017 and 2024 sheet materials because of the effect on their resistance to corrosion.

Lag Between Soaking and Quenching

The time interval between the removal of the material from the furnace and quenching is critical for some alloys and should be held to a minimum. When solution heat treating 2017 or 2024 sheet material, the elapsed time must not exceed 10 seconds. The allowable time for heavy sections may be slightly greater.

Allowing the metal to cool slightly before quenching promotes reprecipitation from the solid solution. The precipitation occurs along grain boundaries and in certain slip planes causing poorer formability. In the case of 2017, 2024, and 7075 alloys, their resistance to intergranular corrosion is adversely affected.

Reheat Treatment

The treatment of material which has been previously heat treated is considered a reheat treatment. The unclad heat-treatable alloys can be solution heat treated repeatedly without harmful effects.

The number of solution heat treatments allowed for clad sheet is limited due to increased diffusion of core and cladding with each reheating. Existing specifications allow one to three reheat treatments of clad sheet depending upon cladding thickness.

Straightening After Solution Heat Treatment

Some warping occurs during solution heat treatment, producing kinks, buckles, waves, and twists. These imperfections are generally removed by straightening and flattening operations.

Where the straightening operations produce an appreciable increase in the tensile and yield strengths and a slight decrease in the percent of elongation, the material is designated -T3 temper. When the above values are not materially affected, the material is designated -T4 temper.

Precipitation Heat Treating

As previously stated, the aluminum alloys are in a comparatively soft state immediately after quenching from a solution heat-treating temperature. To obtain their maximum strengths, they must be either naturally aged or precipitation hardened.

During this hardening and strengthening operation, precipitation of the soluble constituents from the super-saturated solid solution takes place. As precipitation

progresses, the strength of the material increases, often by a series of peaks, until a maximum is reached. Further aging (overaging) causes the strength to steadily decline until a somewhat stable condition is obtained. The submicroscopic particles that are precipitated provide the keys or locks within the grain structure and between the grains to resist internal slippage and distortion when a load of any type is applied. In this manner, the strength and hardness of the alloy are increased.

Precipitation hardening produces a great increase in the strength and hardness of the material with corresponding decreases in the ductile properties. The process used to obtain the desired increase in strength is therefore known as aging, or precipitation hardening.

The strengthening of the heat-treatable alloys by aging is not due merely to the presence of a precipitate. The strength is due to both the uniform distribution of a finely dispersed submicroscopic precipitate and its effects upon the crystal structure of the alloy.

The aging practices used depend upon many properties other than strength. As a rule, the artificially aged alloys are slightly overaged to increase their resistance to corrosion. This is especially true with the artificially aged high copper content alloys that are susceptible to intergranular corrosion when inadequately aged.

The heat-treatable aluminum alloys are subdivided into two classes: those that obtain their full strength at room temperature and those that require artificial aging.

The alloys that obtain their full strength after 4 or 5 days at room temperature are known as natural aging alloys. Precipitation from the supersaturated solid solution starts soon after quenching, with 90 percent of the

maximum strength generally being obtained in 24 hours. Alloys 2017 and 2024 are natural aging alloys.

The alloys that require precipitation thermal treatment to develop their full strength are artificially aged alloys. However, these alloys also age a limited amount at room temperature, the rate and extent of the strengthening depending upon the alloys.

Many of the artificially aged alloys reach their maximum natural or room temperature aging strengths after a few days. These can be stocked for fabrication in the -T4 or -T3 temper. High zinc content alloys such as 7075 continue to age appreciably over a long period of time, their mechanical property changes being sufficient to reduce their formability.

The advantage of -W temper formability can be utilized, however, in the same manner as with natural aging alloys; that is, by fabricating shortly after solution heat treatment, or retaining formability by the use of refrigeration.

Refrigeration retards the rate of natural aging. At 32 °F, the beginning of the aging process is delayed for several hours, while dry ice (-50 °F to -100 °F) retards aging for an extended period of time.

Precipitation Practices

The temperatures used for precipitation hardening depend upon the alloy and the properties desired, ranging from 250 °F to 375 °F. They should be controlled within a very narrow range (± 5 °F) to obtain best results. [Figure 5-8]

The time at temperature is dependent upon the temperature used, the properties desired, and the alloy. It ranges from 8 to 96 hours. Increasing the aging tem-

Alloy	Solution heat treatment			Precipitation heat treatment		
	Temperature (°F)	Quench	Temperature designation	Temperature (°F)	Time of aging	Temperature designation
2017	930-950	Cold water	T4			T
2117	930-950	Cold water	T4			T
2024	910-930	Cold water	T4			T
6053	960-980	Water	T4	445-455 345-355	1-2 hours or 8 hours	T5 T6
6061	960-980	Water	T4	315-325 345-355	18 hours or 8 hours	T6 T6
7075	870	Water		250	24 hours	T6

Figure 5-8. Conditions for heat treatment of aluminum alloys.

perature decreases the soaking period necessary for proper aging. However, a closer control of both time and temperature is necessary when using the higher temperatures.

After receiving the thermal precipitation treatment, the material should be air cooled to room temperature. Water quenching, while not necessary, produces no ill effects. Furnace cooling has a tendency to produce overaging.

Annealing of Aluminum Alloys

The annealing procedure for aluminum alloys consists of heating the alloys to an elevated temperature, holding or soaking them at this temperature for a length of time depending upon the mass of the metal, and then cooling in still air. Annealing leaves the metal in the best condition for cold working. However, when prolonged forming operations are involved, the metal will take on a condition known as “mechanical hardness” and will resist further working. It may be necessary to anneal a part several times during the forming process to avoid cracking. Aluminum alloys should not be used in the annealed state for parts or fittings.

Clad parts should be heated as quickly and carefully as possible, since long exposure to heat tends to cause some of the constituents of the core to diffuse into the cladding. This reduces the corrosion resistance of the cladding.

Heat Treatment of Aluminum Alloy Rivets

Aluminum alloy rivets are furnished in the following compositions: Alloys 1100, 5056, 2117, 2017, and 2024.

Alloy 1100 rivets are used in the “as fabricated” condition for riveting aluminum alloy sheets where a low strength rivet is suitable. Alloy 5056 rivets are used in the “as fabricated” condition for riveting magnesium alloy sheets.

Alloy 2117 rivets have moderately high strength and are suitable for riveting aluminum alloy sheets. These rivets receive only one heat treatment, which is performed by the manufacturer, and are anodized after being heat treated. They require no further heat treatment before they are used. Alloy 2117 rivets retain their characteristics indefinitely after heat treatment and can be driven anytime. Rivets made of this alloy are the most widely used in aircraft construction.

Alloy 2017 and 2024 rivets are high strength rivets suitable for use with aluminum alloy structures. They are purchased from the manufacturer in the heat-treated condition. Since the aging characteristics of these

alloys at room temperatures are such that the rivets are unfit for driving, they must be reheat treated just before they are to be used. Alloy 2017 rivets become too hard for driving in approximately 1 hour after quenching. Alloy 2024 rivets become hardened in 10 minutes after quenching. Both of these alloys may be reheat treated as often as required; however, they must be anodized before the first reheat treatment to prevent intergranular oxidation of the material. If these rivets are stored in a refrigerator at a temperature lower than 32 °F immediately after quenching, they will remain soft enough to be usable for several days.

Rivets requiring heat treatment are heated either in tubular containers in a salt bath, or in small screen wire baskets in an air furnace. The heat treatment of alloy 2017 rivets consists of subjecting the rivets to a temperature between 930 °F to 950 °F for approximately 30 minutes, and immediately quenching in cold water. These rivets reach maximum strength in about 9 days after being driven. Alloy 2024 rivets should be heated to a temperature of 910 °F to 930 °F and immediately quenched in cold water. These rivets develop a greater shear strength than 2017 rivets and are used in locations where extra strength is required. Alloy 2024 rivets develop their maximum shear strength in 1 day after being driven.

The 2017 rivet should be driven within approximately 1 hour and the 2024 rivet within 10 to 20 minutes after heat treating or removal from refrigeration. If not used within these times, the rivets should be re-heat treated before being refrigerated.

Heat Treatment of Magnesium Alloys

Magnesium alloy castings respond readily to heat treatment, and about 95 percent of the magnesium used in aircraft construction is in the cast form. The heat treatment of magnesium alloy castings is similar to the heat treatment of aluminum alloys in that there are two types of heat treatment: (1) solution heat treatment and (2) precipitation (aging) heat treatment. Magnesium, however, develops a negligible change in its properties when allowed to age naturally at room temperatures.

Solution Heat Treatment

Magnesium alloy castings are solution heat treated to improve tensile strength, ductility, and shock resistance. This heat-treatment condition is indicated by using the symbol -T4 following the alloy designation. Solution heat treatment plus artificial aging is designated -T6. Artificial aging is necessary to develop the full properties of the metal.

Solution heat-treatment temperatures for magnesium alloy castings range from 730 °F to 780 °F, the exact range depending upon the type of alloy. The temperature range for each type of alloy is listed in Specification MIL-H-6857. The upper limit of each range listed in the specification is the maximum temperature to which the alloy may be heated without danger of melting the metal.

The soaking time ranges from 10 to 18 hours, the exact time depending upon the type of alloy as well as the thickness of the part. Soaking periods longer than 18 hours may be necessary for castings over 2 inches in thickness. **NEVER** heat magnesium alloys in a salt bath as this may result in an explosion.

A serious potential fire hazard exists in the heat treatment of magnesium alloys. If through oversight or malfunctioning of equipment, the maximum temperatures are exceeded, the casting may ignite and burn freely. For this reason, the furnace used should be equipped with a safety cutoff that will turn off the power to the heating elements and blowers if the regular control equipment malfunctions or fails. Some magnesium alloys require a protective atmosphere of sulfur dioxide gas during solution heat treatment. This aids in preventing the start of a fire even if the temperature limits are slightly exceeded.

Air quenching is used after solution heat treatment of magnesium alloys since there appears to be no advantage in liquid cooling.

Precipitation Heat Treatment

After solution treatment, magnesium alloys may be given an aging treatment to increase hardness and yield strength. Generally, the aging treatments are used merely to relieve stress and stabilize the alloys in order to prevent dimensional changes later, especially during or after machining. Both yield strength and hardness are improved somewhat by this treatment at the expense of a slight amount of ductility. The corrosion resistance is also improved, making it closer to the “as cast” alloy.

Precipitation heat treatment temperatures are considerably lower than solution heat-treatment temperatures and range from 325 °F to 500 °F. Soaking time ranges from 4 to 18 hours.

Heat Treatment of Titanium

Titanium is heat treated for the following purposes:

- Relief of stresses set up during cold forming or machining.

- Annealing after hot working or cold working, or to provide maximum ductility for subsequent cold working.
- Thermal hardening to improve strength.

Stress Relieving

Stress relieving is generally used to remove stress concentrations resulting from forming of titanium sheet. It is performed at temperatures ranging from 650 °F to 1,000 °F. The time at temperature varies from a few minutes for a very thin sheet to an hour or more for heavier sections. A typical stress relieving treatment is 900 °F for 30 minutes, followed by an air cool.

The discoloration or scale which forms on the surface of the metal during stress relieving is easily removed by pickling in acid solutions. The recommended solution contains 10 to 20 percent nitric acid and 1 to 3 percent hydrofluoric acid. The solution should be at room temperature or slightly above.

Full Annealing

The annealing of titanium and titanium alloys provides toughness, ductility at room temperature, dimensional and structural stability at elevated temperatures, and improved machinability.

The full anneal is usually called for as preparation for further working. It is performed at 1,200–1,650 °F. The time at temperature varies from 16 minutes to several hours, depending on the thickness of the material and the amount of cold work to be performed. The usual treatment for the commonly used alloys is 1,300 °F for 1 hour, followed by an air cool. A full anneal generally results in sufficient scale formation to require the use of caustic descaling, such as sodium hydride salt bath.

Thermal Hardening

Unalloyed titanium cannot be heat treated, but the alloys commonly used in aircraft construction can be strengthened by thermal treatment, usually at some sacrifice in ductility. For best results, a water quench from 1,450 °F, followed by reheating to 900 °F for 8 hours is recommended.

Casehardening

The chemical activity of titanium and its rapid absorption of oxygen, nitrogen, and carbon at relatively low temperatures make casehardening advantageous for special applications. Nitriding, carburizing, or carbonitriding can be used to produce a wear-resistant case of 0.0001 to 0.0002 inch in depth.

Hardness Testing

Hardness testing is a method of determining the results of heat treatment as well as the state of a metal prior to heat treatment. Since hardness values can be tied in with tensile strength values and, in part, with wear resistance, hardness tests are a valuable check of heat-treat control and of material properties.

Practically all hardness testing equipment now uses the resistance to penetration as a measure of hardness. Included among the better known hardness testers are the Brinell and Rockwell, both of which are described and illustrated in this section. Also included is a popular portable-type hardness tester currently in use.

Brinell Tester

The Brinell hardness tester [Figure 5-9] uses a hardened spherical ball, which is forced into the surface of the metal. This ball is 10 millimeters (0.3937 inch) in diameter. A pressure of 3,000 kilograms is used for fer-

rous metals and 500 kilograms for nonferrous metals. The pressure must be maintained at least 10 seconds for ferrous metals and at least 30 seconds for nonferrous metals. The load is applied by hydraulic pressure. The hydraulic pressure is built up by a hand pump or an electric motor, depending on the model of tester. A pressure gauge indicates the amount of pressure. There is a release mechanism for relieving the pressure after the test has been made, and a calibrated microscope is provided for measuring the diameter of the impression in millimeters. The machine has various shaped anvils for supporting the specimen and an elevating screw for bringing the specimen in contact with the ball penetrator. These are attachments for special tests.

To determine the Brinell hardness number for a metal, measure the diameter of the impression, using the calibrated microscope furnished with the tester. Then convert the measurement into the Brinell hardness number on the conversion table furnished with the tester.

Rockwell Tester

The Rockwell hardness tester [Figure 5-10] measures the resistance to penetration, as does the Brinell tester. Instead of measuring the diameter of the impres-

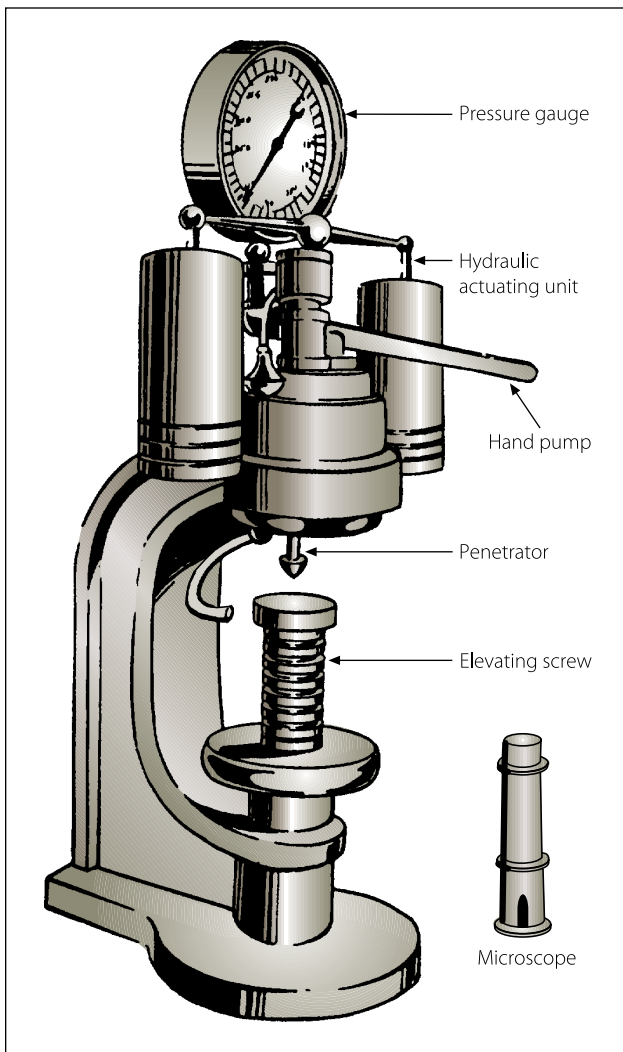

Figure 5-9. Brinell hardness tester.

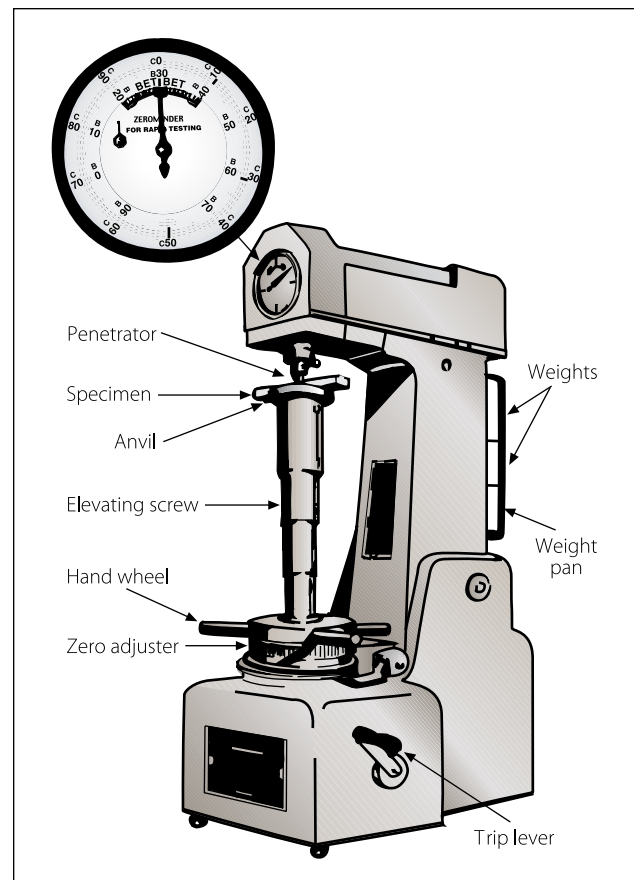

Figure 5-10. Rockwell hardness tester.

sion, the Rockwell tester measures the depth, and the hardness is indicated directly on a dial attached to the machine. The dial numbers in the outer circle are black, and the inner numbers are red. Rockwell hardness numbers are based on the difference between the depth of penetration at major and minor loads. The greater this difference, the lower the hardness number and the softer the material.

Two types of penetrators are used with the Rockwell tester: a diamond cone and a hardened steel ball. The load which forces the penetrator into the metal is called the major load and is measured in kilograms. The results of each penetrator and load combination are reported on separate scales, designated by letters. The penetrator, the major load, and the scale vary with the kind of metal being tested.

For hardened steels, the diamond penetrator is used; the major load is 150 kilograms; and the hardness is read on the “C” scale. When this reading is recorded, the letter “C” must precede the number indicated by the pointer. The C-scale setup is used for testing metals ranging in hardness from C-20 to the hardest steel (usually about C-70). If the metal is softer than C-20, the B-scale setup is used. With this setup, the 1/16-inch ball is used as a penetrator; the major load is 100 kilograms; and the hardness is read on the B-scale.

In addition to the “C” and “B” scales, there are other setups for special testing. The scales, penetrators, major loads, and dial numbers to be read are listed in Figure 5-11.

The Rockwell tester is equipped with a weight pan, and two weights are supplied with the machine. One weight is marked in red. The other weight is marked in black. With no weight in the weight pan, the machine applies a major load of 60 kilograms. If the scale setup calls for a 100 kilogram load, the red weight is placed in the pan. For a 150 kilogram load, the black weight is added to the red weight. The black weight is always used with the red weight; it is never used alone.

Practically all testing is done with either the B-scale setup or the C-scale setup. For these scales, the colors may be used as a guide in selecting the weight (or weights) and in reading the dial. For the B-scale test, use the red weight and read the red numbers. For a C-scale test, add the black weight to the red weight and read the black numbers.

In setting up the Rockwell machine, use the diamond penetrator for testing materials known to be hard. If the hardness is unknown, try the diamond, since the

Scale Symbol	Penetrator	Major Load (kg)	Dial Color/Number
A	Diamond	60	Black
B	1/16-inch ball	100	Red
C	Diamond	150	Black
D	Diamond	100	Black
E	1/8-inch ball	100	Red
F	1/16-inch ball	60	Red
G	1/16-inch ball	150	Red
H	1/8-inch ball	60	Red
K	1/8-inch ball	150	Red

Figure 5-11. Standard Rockwell hardness scales.

steel ball may be deformed if used for testing hard materials. If the metal tests below C-22, then change to the steel ball.

Use the steel ball for all soft materials, those testing less than B-100. Should an overlap occur at the top of the B-scale and the bottom of the C-scale, use the C-scale setup.

Before the major load is applied, securely lock the test specimen in place to prevent slipping and to seat the anvil and penetrator properly. To do this, apply a load of 10 kilograms before the lever is tripped. This preliminary load is called the minor load. The minor load is 10 kilograms regardless of the scale setup.

The metal to be tested in the Rockwell tester must be ground smooth on two opposite sides and be free of scratches and foreign matter. The surface should be perpendicular to the axis of penetration, and the two opposite ground surfaces should be parallel. If the specimen is tapered, the amount of error will depend on the taper. A curved surface will also cause a slight error in the hardness test. The amount of error depends on the curvature; i.e., the smaller the radius of curvature, the greater the error. To eliminate such error, a small flat should be ground on the curved surface if possible.

Clad aluminum alloy sheets cannot be tested directly with any accuracy with a Rockwell hardness tester. If the hardness value of the base metal is desired, the pure aluminum coating must be removed from the area to be checked prior to testing.

Barcol Tester

The Barcol tester [Figure 5-12] is a portable unit designed for testing aluminum alloys, copper, brass, or other relatively soft materials. It should not be used on



Figure 5-12. Barcol portable hardness tester.

aircraft steels. Approximate range of the tester is 25 to 100 Brinell. The unit can be used in any position and in any space that will allow for the operator's hand. It is of great value in the hardness testing of assembled or installed parts, especially to check for proper heat treatment. The hardness is indicated on a dial conveniently divided into 100 graduations.

The design of the Barcol tester is such that operating experience is not necessary. It is only necessary to exert a light pressure against the instrument to drive the spring loaded indenter into the material to be tested. The hardness reading is instantly indicated on the dial.

Several typical readings for aluminum alloys are listed in Figure 5-13. Note that the harder the material is, the higher the Barcol number will be. To prevent damage to the point, avoid sliding or scraping when it is in contact with the material being tested. If the point should become damaged, it must be replaced with a new one. Do not attempt to grind the point.

Each tester is supplied with a test disk for checking the condition of the point. To check the point, press the instrument down on the test disk. When the downward pressure brings the end of the lower plunger guide against the surface of the disk, the indicator reading should be within the range shown on the test disk.

Alloy and Temper	Barcol Number
1100-O	35
3003-O	42
3003-H14	56
2024-O	60
5052-O	62
5052-H34	75
6061-T	78
2024-T	85

Figure 5-13. Typical Barcol readings for aluminum alloy.

Forging

Forging is the process of forming a product by hammering or pressing. When the material is forged below the recrystallization temperature, it is called cold forged. When worked above the recrystallization temperature, it is referred to as hot forged. Drop forging is a hammering process that uses a hot ingot that is placed between a pair of formed dies in a machine called a drop hammer and a weight of several tons is dropped on the upper die. This results in the hot metal being forced to take the form of the dies. Because the process is very rapid, the grain structure of the metal is altered, resulting in a significant increase in the strength of the finished part.

Casting

Casting is formed by melting the metal and pouring it into a mold of the desired shape. Since plastic deformation of the metal does not occur, no alteration of the grain shape or orientation is possible. The grain size of the metal can be controlled by the cooling rate, the alloys of the metal, and the thermal treatment. Castings are normally lower in strength and are more brittle than a wrought product of the same material. For intricate shapes or items with internal passages, such as turbine blades, casting may be the most economical process. Except for engine parts, most metal components found on an aircraft are wrought instead of cast.

All metal products start in the form of casting. Wrought metals are converted from cast ingots by plastic deformation. For high strength aluminum alloys, an 80 to 90 percent reduction (dimensional change in thickness) of the material is required to obtain the high mechanical properties of a fully wrought structure.

Both iron and aluminum alloys are cast for aircraft uses. Cast iron contains 6 to 8 percent carbon and silicon.

Cast iron is a hard unmalleable pig iron made by casting or pouring into a mold. Cast aluminum alloy has been heated to its molten state and poured into a mold to give it the desired shape.

Extruding

The extrusion process involves the forcing of metal through an opening in a die, thus causing the metal to take the shape of the die opening. The shape of the die will be the cross section of an angle, channel, tube, or some other shape. Some metals such as lead, tin, and aluminum may be extruded cold; however, most metals are heated before extrusion. The main advantage of the extrusion process is its flexibility. For example, because of its workability, aluminum can be economically extruded to more intricate shapes and larger sizes than is practical with other metals.

Extruded shapes are produced in very simple as well as extremely complex sections. In this process a cylinder of aluminum, for instance, is heated to 750–850 °F and is then forced through the opening of a die by a hydraulic ram. The opening is the shape desired for the cross section of the finished extrusion.

Many structural parts, such as channels, angles, T-sections, and Z-sections, are formed by the extrusion process.

Aluminum is the most extruded metal used in aircraft. Aluminum is extruded at a temperature of 700–900 °F (371–482 °C) and requires pressure of up to 80,000 psi (552 MPa). After extrusion, the product frequently will be subjected to both thermal and mechanical processes to obtain the desired properties. Extrusion processes are limited to the more ductile materials.

Cold Working/Hardening

Cold working applies to mechanical working performed at temperatures below the critical range. It results in a strain hardening of the metal. In fact, the metal often becomes so hard that it is difficult to continue the forming process without softening the metal by annealing.

Since the errors attending shrinkage are eliminated in cold working, a much more compact and better metal is obtained. The strength and hardness, as well as the elastic limit, are increased; but the ductility decreases. Since this makes the metal more brittle, it must be heated from time to time during certain operations to remove the undesirable effects of the working.

While there are several cold working processes, the two with which the aviation mechanic will be principally

concerned are cold rolling and cold drawing. These processes give the metals desirable qualities which cannot be obtained by hot working.

Cold rolling usually refers to the working of metal at room temperature. In this operation, the materials that have been rolled to approximate sizes are pickled to remove the scale, after which they are passed through chilled finishing rolls. This gives a smooth surface and also brings the pieces to accurate dimensions. The principal forms of cold rolled stocks are sheets, bars, and rods.

Cold drawing is used in making seamless tubing, wire, streamlined tie rods, and other forms of stock. Wire is made from hot rolled rods of various diameters. These rods are pickled in acid to remove scale, dipped in lime water, and then dried in a steam room where they remain until ready for drawing. The lime coating adhering to the metal serves as a lubricant during the drawing operation.

The size of the rod used for drawing depends upon the diameter wanted in the finished wire. To reduce the rod to the desired size, it is drawn cold through a die. One end of the rod is filed or hammered to a point and slipped through the die opening. Here it is gripped by the jaws of the drawing block and pulled through the die. This series of operations is done by a mechanism known as a drawbench.

To reduce the rod gradually to the desired size, it is necessary to draw the wire through successively smaller dies. Because each of these drawings reduces the ductility of the wire, it must be annealed from time to time before further drawings can be accomplished. Although cold working reduces the ductility, it increases the tensile strength of the wire.

In making seamless steel aircraft tubing, the tubing is cold drawn through a ring shaped die with a mandrel or metal bar inside the tubing to support it while the drawing operations are being performed. This forces the metal to flow between the die and the mandrel and affords a means of controlling the wall thickness and the inside and outside diameters.

Nonmetallic Aircraft Materials

The use of magnesium, plastic, fabric, and wood in aircraft construction has nearly disappeared since the mid-1950s. Aluminum has also greatly diminished in use, from 80 percent of airframes in 1950 to about 15 percent aluminum and aluminum alloys today for airframe construction. Replacing those materials are

nonmetallic aircraft materials, such as reinforced plastics and advanced composites.

Wood

The earliest aircraft were constructed of wood and cloth. Today, except for restorations and some home-built aircraft, very little wood is used in aircraft construction.

Plastics

Plastics are used in many applications throughout modern aircraft. These applications range from structural components of thermosetting plastics reinforced with fiberglass to decorative trim of thermoplastic materials to windows.

Transparent Plastics

Transparent plastic materials used in aircraft canopies, windshields, windows and other similar transparent enclosures may be divided into two major classes or groups. These plastics are classified according to their reaction to heat. The two classes are: thermoplastic and thermosetting.

Thermoplastic materials will soften when heated and harden when cooled. These materials can be heated until soft, and then formed into the desired shape. When cooled, they will retain this shape. The same piece of plastic can be reheated and reshaped any number of times without changing the chemical composition of the materials.

Thermosetting plastics harden upon heating, and reheating has no softening effect. These plastics cannot be reshaped once being fully cured by the application of heat.

In addition to the above classes, transparent plastics are manufactured in two forms: monolithic (solid) and laminated. Laminated transparent plastics are made from transparent plastic face sheets bonded by an inner layer material, usually polyvinyl butyryl. Because of its shatter resistant qualities, laminated plastic is superior to solid plastics and is used in many pressurized aircraft.

Most of the transparent sheet used in aviation is manufactured in accordance with various military specifications. A new development in transparent plastics is stretched acrylic. Stretched acrylic is a type of plastic which, before being shaped, is pulled in both directions to rearrange its molecular structure. Stretched acrylic panels have a greater resistance to impact and are less subject to shatter; its chemical resistance is greater,

edging is simpler, and crazing and scratches are less detrimental.

Individual sheets of plastic are covered with a heavy masking paper to which a pressure sensitive adhesive has been added. This paper helps to prevent accidental scratching during storage and handling. Be careful to avoid scratches and gouges which may be caused by sliding sheets against one another or across rough or dirty tables.

If possible, store sheets in bins which are tilted at approximately 10° from vertical. If they must be stored horizontally, piles should not be over 18 inches high, and small sheets should be stacked on the larger ones to avoid unsupported overhang. Store in a cool, dry place away from solvent fumes, heating coils, radiators, and steam pipes. The temperature in the storage room should not exceed 120 °F.

While direct sunlight does not harm acrylic plastic, it will cause drying and hardening of the masking adhesive, making removal of the paper difficult. If the paper will not roll off easily, place the sheet in an oven at 250 °F for 1 minute, maximum. The heat will soften the masking adhesive for easy removal of the paper.

If an oven is not available, remove hardened masking paper by softening the adhesive with aliphatic naphtha. Rub the masking paper with a cloth saturated with naphtha. This will soften the adhesive and free the paper from the plastic. Sheets so treated must be washed immediately with clean water, taking care not to scratch the surfaces.

Note: Aliphatic naphtha is not to be confused with aromatic naphtha and other dry cleaning solvents which have harmful effects on plastic. However, aliphatic naphtha is flammable and all precautions regarding the use of flammable liquids must be observed.

Composite Materials

In the 1940s, the aircraft industry began to develop synthetic fibers to enhance aircraft design. Since that time, composite materials have been used more and more. When composites are mentioned, most people think of only fiberglass, or maybe graphite or aramids (Kevlar). Composites began in aviation, but now are being embraced by many other industries, including auto racing, sporting goods, and boating, as well as defense industry uses.

A “composite” material is defined as a mixture of different materials or things. This definition is so general that it could refer to metal alloys made from several

different metals to enhance the strength, ductility, conductivity or whatever characteristics are desired. Likewise, the composition of composite materials is a combination of reinforcement, such as a fiber, whisker, or particle, surrounded and held in place by a resin, forming a structure. Separately, the reinforcement and the resin are very different from their combined state. Even in their combined state, they can still be individually identified and mechanically separated. One composite, concrete, is composed of cement (resin) and gravel or reinforcement rods for the reinforcement to create the concrete.

Advantages/Disadvantages of Composites

Some of the many advantages for using composite materials are:

- High strength to weight ratio
- Fiber-to-fiber transfer of stress allowed by chemical bonding
- Modulus (stiffness to density ratio) 3.5 to 5 times that of steel or aluminum
- Longer life than metals
- Higher corrosion resistance
- Tensile strength 4 to 6 times that of steel or aluminum
- Greater design flexibility
- Bonded construction eliminates joints and fasteners
- Easily repairable

The disadvantages of composites include:

- Inspection methods difficult to conduct, especially delamination detection (Advancements in technology will eventually correct this problem.)
- Lack of long term design database, relatively new technology methods
- Cost
- Very expensive processing equipment
- Lack of standardized system of methodology
- Great variety of materials, processes, and techniques
- General lack of repair knowledge and expertise
- Products often toxic and hazardous
- Lack of standardized methodology for construction and repairs

The increased strength and the ability to design for the performance needs of the product makes composites

much superior to the traditional materials used in today's aircraft. As more and more composites are used, the costs, design, inspection ease, and information about strength to weight advantages will help composites become the material of choice for aircraft construction.

Composite Safety

Composite products can be very harmful to the skin, eyes, and lungs. In the long or short term, people can become sensitized to the materials with serious irritation and health issues. Personal protection is often uncomfortable, hot, and difficult to wear; however, a little discomfort while working with the composite materials can prevent serious health issues or even death.

Respirator particle protection is very important to protecting the lungs from permanent damage from tiny glass bubbles and fiber pieces. At a minimum, a dust mask approved for fiberglass is a necessity. The best protection is a respirator with dust filters. The proper fit of a respirator or dust mask is very important because if the air around the seal is breathed, the mask cannot protect the wearer's lungs. When working with resins, it is important to use vapor protection. Charcoal filters in a respirator will remove the vapors for a period of time. If you can smell the resin vapors after placing the mask back on after a break, replace the filters immediately. Sometimes, charcoal filters last less than 4 hours. Store the respirator in a sealed bag when not in use. If working with toxic materials for an extended period of time, a supplied air mask and hood are recommended.

Avoid skin contact with the fibers and other particles by wearing long pants and long sleeves along with gloves or barrier creams. The eyes must be protected using leak-proof goggles (no vent holes) when working with resins or solvents because chemical damage to the eyes is usually irreversible.

Fiber Reinforced Materials

The purpose of reinforcement in reinforced plastics is to provide most of the strength. The three main forms of fiber reinforcements are particles, whiskers, and fibers.

A particle is a square piece of material. Glass bubbles (Q-cell) are hollow glass spheres, and since their dimensions are equal on all axes, they are called a particle.

A whisker is a piece of material that is longer than it is wide. Whiskers are usually single crystals. They are very strong and used to reinforce ceramics and metals.

Fibers are single filaments that are much longer than they are wide. Fibers can be made of almost any material, and are not crystalline like whiskers. Fibers are the base for most composites. Fibers are smaller than the finest human hair and are normally woven into cloth-like materials.

Laminated Structures

Composites can be made with or without an inner core of material. Laminated structure with a core center is called a sandwich structure. Laminate construction is strong and stiff, but heavy. The sandwich laminate is equal in strength, and its weight is much less; less weight is very important to aerospace products.

The core of a laminate can be made from nearly anything. The decision is normally based on use, strength, and fabricating methods to be used.

Various types of cores for laminated structures include rigid foam, wood, metal, or the aerospace preference of honeycomb made from paper, Nomex, carbon, fiberglass or metal. Figure 5-14 shows a typical sandwich structure. It is very important to follow proper techniques to construct or repair laminated structures to ensure the strength is not compromised. A sandwich assembly is made by taking a high-density laminate or solid face and backplate and sandwiching a core in the middle. The selection of materials for the face and backplate are decided by the design engineer, depending on the intended application of the part. It is important to follow manufacturers' maintenance manual specific instructions regarding testing and repair procedures as they apply to a particular aircraft.

Reinforced Plastic

Reinforced plastic is a thermosetting material used in the manufacture of radomes, antenna covers, and wingtips, and as insulation for various pieces of electrical equipment and fuel cells. It has excellent dielectric characteristics which make it ideal for radomes; however, its high strength-to-weight ratio, resistance to mildew, rust, and rot, and ease of fabrication make it equally suited for other parts of the aircraft.

Reinforced plastic components of aircraft are formed of either solid laminates or sandwich-type laminates. Resins used to impregnate glass cloths are of the contact pressure type (requiring little or no pressure during cure). These resins are supplied as a liquid which can vary in viscosity from a waterlike consistency to a thick syrup. Cure or polymerization is effected by the use of a catalyst, usually benzoyl peroxide.

Solid laminates are constructed of three or more layers of resin impregnated cloths "wet laminated" together to form a solid sheet facing or molded shape.

Sandwich-type laminates are constructed of two or more solid sheet facings or a molded shape enclosing a fiberglass honeycomb or foam-type core. Honeycomb cores are made of glass cloths impregnated with a polyester or a combination of nylon and phenolic resins. The specific density and cell size of honeycomb cores varies over a considerable latitude. Honeycomb cores are normally fabricated in blocks that are later cut to the desired thickness on a bandsaw.

Foam-type cores are formulated from combinations of alkyd resins and metatoluene di-isocyanate. Sandwich-type fiberglass components filled with foam-type cores

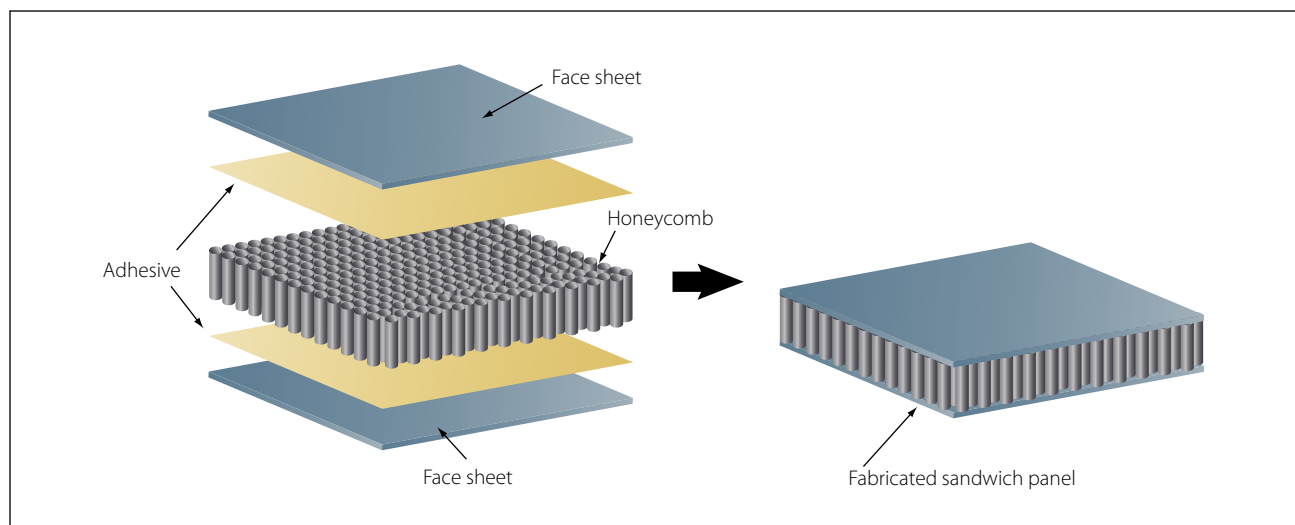

Figure 5-14. Sandwich structure.

are manufactured to exceedingly close tolerances on overall thickness of the molded facing and core material. To achieve this accuracy, the resin is poured into a close tolerance, molded shape. The resin formulation immediately foams up to fill the void in the molded shape and forms a bond between the facing and the core.

Rubber

Rubber is used to prevent the entrance of dirt, water, or air, and to prevent the loss of fluids, gases, or air. It is also used to absorb vibration, reduce noise, and cushion impact loads.

The term “rubber” is as all inclusive as the term “metal.” It is used to include not only natural rubber, but all synthetic and silicone rubbers.

Natural Rubber

Natural rubber has better processing and physical properties than synthetic or silicone rubber. These properties include: flexibility, elasticity, tensile strength, tear strength, and low heat buildup due to flexing (hysteresis). Natural rubber is a general purpose product; however, its suitability for aircraft use is somewhat limited because of its inferior resistance to most influences that cause deterioration. Although it provides an excellent seal for many applications, it swells and often softens in all aircraft fuels and in many solvents (naphthas, and so forth). Natural rubber deteriorates more rapidly than synthetic rubber. It is used as a sealing material for water/methanol systems.

Synthetic Rubber

Synthetic rubber is available in several types, each of which is compounded of different materials to give the desired properties. The most widely used are the butyls, Bunas, and neoprene.

Butyl is a hydrocarbon rubber with superior resistance to gas permeation. It is also resistant to deterioration; however, its comparative physical properties are significantly less than those of natural rubber. Butyl will resist oxygen, vegetable oils, animal fats, alkalies, ozone, and weathering.

Like natural rubber, butyl will swell in petroleum or coal tar solvents. It has a low water absorption rate and good resistance to heat and low temperature. Depending on the grade, it is suitable for use in temperatures ranging from -65°F to 300°F . Butyl is used with phosphate ester hydraulic fluids (Skydrol), silicone fluids, gases, ketones, and acetones.

Buna-S rubber resembles natural rubber both in processing and performance characteristics. Buna-S is as water resistant as natural rubber, but has somewhat better aging characteristics. It has good resistance to heat, but only in the absence of severe flexing. Generally, Buna-S has poor resistance to gasoline, oil, concentrated acids, and solvents. Buna-S is normally used for tires and tubes as a substitute for natural rubber.

Buna-N is outstanding in its resistance to hydrocarbons and other solvents; however, it has poor resilience in solvents at low temperature. Buna-N compounds have good resistance to temperatures up to 300°F , and may be procured for low temperature applications down to -75°F . Buna-N has fair tear, sunlight, and ozone resistance. It has good abrasion resistance and good breakaway properties when used in contact with metal. When used as a seal on a hydraulic piston, it will not stick to the cylinder wall. Buna-N is used for oil and gasoline hose, tank linings, gaskets, and seals.

Neoprene can take more punishment than natural rubber and has better low temperature characteristics. It possesses exceptional resistance to ozone, sunlight, heat, and aging. Neoprene looks and feels like rubber. Neoprene, however, is less like rubber in some of its characteristics than butyl or Buna. The physical characteristics of neoprene, such as tensile strength and elongation, are not equal to natural rubber but do have a definite similarity. Its tear resistance as well as its abrasion resistance is slightly less than that of natural rubber. Although its distortion recovery is complete, it is not as rapid as natural rubber.

Neoprene has superior resistance to oil. Although it is good material for use in nonaromatic gasoline systems, it has poor resistance to aromatic gasolines. Neoprene is used primarily for weather seals, window channels, bumper pads, oil resistant hose, and carburetor diaphragms. It is also recommended for use with FreonsTM and silicate ester lubricants.

Thiokol, known also as polysulfide rubber, has the highest resistance to deterioration but ranks the lowest in physical properties. Thiokol, in general, is not seriously affected by petroleum, hydrocarbons, esters, alcohols, gasoline, or water. Thiokols are ranked low in such physical properties as compression set, tensile strength, elasticity, and tear abrasion resistance. Thiokol is used for oil hose, tank linings for aromatic aviation gasolines, gaskets, and seals.

Silicone rubbers are a group of plastic rubber materials made from silicon, oxygen, hydrogen, and carbon. The silicones have excellent heat stability and very low tem-

perature flexibility. They are suitable for gaskets, seals, or other applications where elevated temperatures up to 600 °F are prevalent. Silicone rubbers are also resistant to temperatures down to -150 °F. Throughout this temperature range, silicone rubber remains extremely flexible and useful with no hardness or gumminess. Although this material has good resistance to oils, it reacts unfavorably to both aromatic and nonaromatic gasolines.

Silastic, one of the best known silicones, is used to insulate electrical and electronic equipment. Because of its dielectric properties over a wide range of temperatures, it remains flexible and free from crazing and cracking. Silastic is also used for gaskets and seals in certain oil systems.

Shock Absorber Cord

Shock absorber cord is made from natural rubber strands encased in a braided cover of woven cotton cords treated to resist oxidation and wear. Great tension and elongation are obtained by weaving the jacket upon the bundle of rubber strands while they are stretched about three times their original length.

There are two types of elastic shock absorbing cord. Type I is a straight cord, and type II is a continuous ring, known as a “bungee.” The advantages of the type II cord are that it is easily and quickly replaced and does not need to be secured by stretching and whipping. Shock cord is available in standard diameters from 1/4 inch to 13/16 inch.

Three colored threads are braided into the outer cover for the entire length of the cord. Two of these threads are of the same color and represent the year of manufacture; the third thread, a different color, represents the quarter of the year in which the cord was made. The code covers a 5-year period and then repeats itself. This makes it easy to figure forward or backward from the years shown in Figure 5-15.

Seals

Seals are used to prevent fluid from passing a certain point, as well as to keep air and dirt out of the system in which they are used. The increased use of hydraulics and pneumatics in aircraft systems has created a need for packings and gaskets of varying characteristics and design to meet the many variations of operating speeds and temperatures to which they are subjected. No one style or type of seal is satisfactory for all installations. Some of the reasons for this are: (1) pressure at which the system operates, (2) the type fluid used in the sys-

Year	Threads	Color
2000	2	black
2001	2	green
2002	2	red
2003	2	blue
2004	2	yellow
2005	2	black
2006	2	green
2007	2	red
2008	2	blue
2009	2	yellow
2010	2	black

Quarter Marking		
Quarter	Threads	Color
Jan., Feb., Mar.	1	red
Apr., May, June	1	blue
July, Aug., Sept.	1	green
Oct., Nov., Dec.	1	yellow

Figure 5-15. Shock absorber cord color coding.

tem, (3) the metal finish and the clearance between adjacent parts, and (4) the type motion (rotary or reciprocating), if any. Seals are divided into three main classes: (1) packings, (2) gaskets, and (3) wipers.

Packings

Packings are made of synthetic or natural rubber. They are generally used as “running seals,” that is, in units that contain moving parts, such as actuating cylinders, pumps, selector valves, and so forth. Packings are made in the form of O-rings, V-rings, and U-rings, each designed for a specific purpose. [Figure 5-16]

O-Ring Packings

O-ring packings are used to prevent both internal and external leakage. This type of packing ring seals effectively in both directions and is the type most commonly used. In installations subject to pressures above 1,500 psi, backup rings are used with O-rings to prevent extrusion.

When an O-ring packing is subjected to pressure from both sides, as in actuating cylinders, two backup rings must be used (one on either side of the O-ring). When an O-ring is subject to pressure on only one side, a

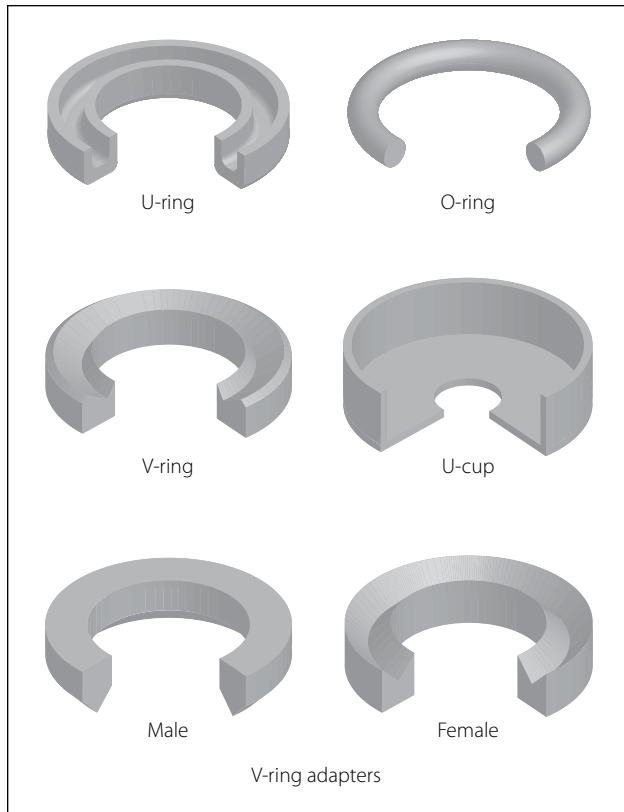

Figure 5-16. Packing rings.

single backup ring is generally used. In this case, the backup ring is always placed on the side of the O-ring away from the pressure.

The materials from which O-rings are manufactured have been compounded for various operating conditions, temperatures, and fluids. An O-ring designed specifically for use as a static (stationary) seal probably will not do the job when installed on a moving part, such as a hydraulic piston. Most O-rings are similar in appearance and texture, but their characteristics may differ widely. An O-ring is useless if it is not compatible with the system fluid and operating temperature.

Advances in aircraft design have necessitated new O-ring compositions to meet changed operating conditions. Hydraulic O-rings were originally established under AN specification numbers (6227, 6230, and 6290) for use in MIL-H-5606 fluid at temperatures ranging from -65°F to $+160^{\circ}\text{F}$. When new designs raised operating temperatures to a possible 275°F , more compounds were developed and perfected.

Recently, a compound was developed that offered improved low temperature performance without sacrificing high temperature performance, rendering the other series obsolete. This superior material was adopted in the MS28775 series. This series is now the

standard for MIL-H-5606 systems in which the temperature may vary from -65°F to $+275^{\circ}\text{F}$.

Manufacturers provide color coding on some O-rings, but this is not a reliable or complete means of identification. The color coding system does not identify sizes, but only system fluid or vapor compatibility and in some cases the manufacturer. Color codes on O-rings that are compatible with MIL-H-5606 fluid will always contain blue, but may also contain red or other colors. Packings and gaskets suitable for use with Skydrol fluid will always be coded with a green stripe, but may also have a blue, grey, red, green, or yellow dot as a part of the color code. Color codes on O-rings that are compatible with hydrocarbon fluid will always contain red, but will never contain blue. A colored stripe around the circumference indicates that the O-ring is a boss gasket seal. The color of the stripe indicates fluid compatibility: red for fuel, blue for hydraulic fluid.

The coding on some rings is not permanent. On others it may be omitted due to manufacturing difficulties or interference with operation. Furthermore, the color coding system provides no means to establish the age of the O-ring or its temperature limitations.

Because of the difficulties with color coding, O-rings are available in individual hermetically sealed envelopes, labeled with all pertinent data. When selecting an O-ring for installation, the basic part number on the sealed envelope provides the most reliable compound identification.

Although an O-ring may appear perfect at first glance, slight surface flaws may exist. These flaws are often capable of preventing satisfactory O-ring performance under the variable operating pressures of aircraft systems; therefore, O-rings should be rejected for flaws that will affect their performance. Such flaws are difficult to detect, and one aircraft manufacturer recommends using a 4 power magnifying glass with adequate lighting to inspect each ring before it is installed.

By rolling the ring on an inspection cone or dowel, the inner diameter surface can also be checked for small cracks, particles of foreign material, or other irregularities that will cause leakage or shorten the life of the O-ring. The slight stretching of the ring when it is rolled inside out will help to reveal some defects not otherwise visible.

Backup Rings

Backup rings (MS28782) made of Teflon™ do not deteriorate with age, are unaffected by any system

fluid or vapor, and can tolerate temperature extremes in excess of those encountered in high pressure hydraulic systems. Their dash numbers indicate not only their size but also relate directly to the dash number of the O-ring for which they are dimensionally suited. They are procurable under a number of basic part numbers, but they are interchangeable; that is, any Teflon™ backup ring may be used to replace any other Teflon™ backup ring if it is of proper overall dimension to support the applicable O-ring. Backup rings are not color coded or otherwise marked and must be identified from package labels.

The inspection of backup rings should include a check to ensure that surfaces are free from irregularities, that the edges are clean cut and sharp, and that scarf cuts are parallel. When checking Teflon™ spiral backup rings, make sure that the coils do not separate more than 1/4 inch when unrestrained.

V-Ring Packings

V-ring packings (AN6225) are one-way seals and are always installed with the open end of the “V” facing the pressure. V-ring packings must have a male and female adapter to hold them in the proper position after installation. It is also necessary to torque the seal retainer to the value specified by the manufacturer of the component being serviced, or the seal may not give satisfactory service. An installation using V-rings is shown in Figure 5-17.

U-Ring Packings

U-ring packings (AN6226) and U-cup packings are used in brake assemblies and brake master cylinders. The U-ring and U-cup will seal pressure in only one direction; therefore, the lip of the packings must face toward the pressure. U-ring packings are primarily low pressure packings to be used with pressures of less than 1,000 psi.

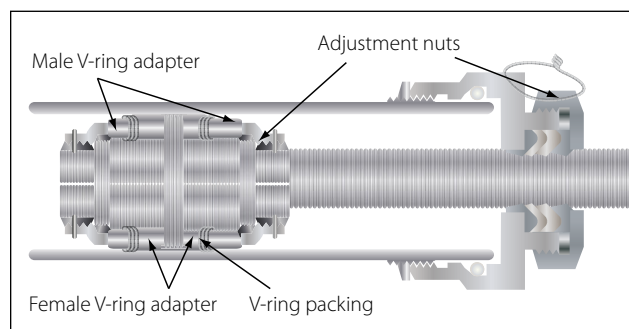

Figure 5-17. V-ring installation.

Gaskets

Gaskets are used as static (stationary) seals between two flat surfaces. Some of the more common gasket materials are asbestos, copper, cork, and rubber. Asbestos sheeting is used wherever a heat resistant gasket is needed. It is used extensively for exhaust system gaskets. Most asbestos exhaust gaskets have a thin sheet of copper edging to prolong their life.

A solid copper washer is used for spark plug gaskets where it is essential to have a noncompressible, yet semisoft gasket.

Cork gaskets can be used as an oil seal between the engine crankcase and accessories, and where a gasket is required that is capable of occupying an uneven or varying space caused by a rough surface or expansion and contraction.

Rubber sheeting can be used where there is a need for a compressible gasket. It should not be used in any place where it may come in contact with gasoline or oil because the rubber will deteriorate very rapidly when exposed to these substances. Gaskets are used in fluid systems around the end caps of actuating cylinders, valves, and other units. The gasket generally used for this purpose is in the shape of an O-ring, similar to O-ring packings.

Wipers

Wipers are used to clean and lubricate the exposed portions of piston shafts. They prevent dirt from entering the system and help protect the piston shaft against scoring.

Wipers may be either metallic or felt. They are sometimes used together, a felt wiper installed behind a metallic wiper.

Sealing Compounds

Certain areas of all aircraft are sealed to withstand pressurization by air, to prevent leakage of fuel, to prevent passage of fumes, or to prevent corrosion by sealing against the weather. Most sealants consist of two or more ingredients properly proportioned and compounded to obtain the best results. Some materials are ready for use as packaged, but others will require mixing before application.

One Part Sealants

One part sealants are prepared by the manufacturer and are ready for application as packaged. However, the consistency of some of these compounds may be altered to satisfy a particular method of application. If

thinning is desired, use the thinner recommended by the sealant manufacturer.

Two Part Sealants

Two part sealants are compounds requiring separate packaging to prevent cure prior to application and are identified as the base sealing compound and the accelerator. Any alteration of the prescribed ratios will reduce the quality of the material. Generally, two-part sealants are mixed by combining equal portions (by weight) of base compound and accelerator.

All sealant material should be carefully weighed in accordance with the sealant manufacturer's recommendations. Sealant material is usually weighed with a balance scale equipped with weights specially prepared for various quantities of sealant and accelerator.

Before weighing the sealant materials, thoroughly stir both the base sealant compound and the accelerator. Do not use accelerator which is dried out, lumpy, or flaky. Preweighed sealant kits do not require weighing of the sealant and accelerator before mixing when the entire quantity is to be mixed.

After determining the proper amount of base sealant compound and accelerator, add the accelerator to the base sealant compound. Immediately after adding the accelerator, thoroughly mix the two parts by stirring or folding, depending on the consistency of the material. Carefully mix the material to prevent entrapment of air in the mixture. Overly rapid or prolonged stirring will build up heat in the mixture and shorten the normal application time (working life) of the mixed sealant.

To ensure a well mixed compound, test by smearing a small portion on a clean, flat metal or glass surface. If flecks or lumps are found, continue mixing. If the flecks or lumps cannot be eliminated, reject the batch.

The working life of mixed sealant is from $\frac{1}{2}$ hour to 4 hours (depending upon the class of sealant); therefore, apply mixed sealant as soon as possible or place in refrigerated storage. Figure 5-18 presents general information concerning various sealants.

The curing rate of mixed sealants varies with changes in temperature and humidity. Curing of sealants will be extremely slow if the temperature is below 60 °F. A temperature of 77 °F with 50 percent relative humidity is the ideal condition for curing most sealants.

Curing may be accelerated by increasing the temperature, but the temperature should never be allowed to exceed 120 °F at any time in the curing cycle. Heat

may be applied by using infrared lamps or heated air. If heated air is used, it must be properly filtered to remove moisture and dirt.

Heat should not be applied to any faying surface sealant installation until all work is completed. All faying surface applications must have all attachments, permanent or temporary, completed within the application limitations of the sealant.

Sealant must be cured to a tack-free condition before applying brush top coatings. (Tack-free consistency is the point at which a sheet of cellophane pressed onto the sealant will no longer adhere.)

Aircraft Hardware

Aircraft hardware is the term used to describe the various types of fasteners and miscellaneous small items used in the manufacture and repair of aircraft. The importance of aircraft hardware is often overlooked because of its small size; however, the safe and efficient operation of any aircraft is greatly dependent upon the correct selection and use of aircraft hardware.

An aircraft, even though made of the best materials and strongest parts, would be of doubtful value unless those parts were firmly held together. Several methods are used to hold metal parts together; they include riveting, bolting, brazing, and welding. The process used must produce a union that will be as strong as the parts that are joined.

Identification

Most items of aircraft hardware are identified by their specification number or trade name. Threaded fasteners and rivets are usually identified by AN (Air Force-Navy), NAS (National Aircraft Standard), or MS (Military Standard) numbers. Quick-release fasteners are usually identified by factory trade names and size designations.

Threaded Fasteners

Various types of fastening devices allow quick dismantling or replacement of aircraft parts that must be taken apart and put back together at frequent intervals. Riveting or welding these parts each time they are serviced would soon weaken or ruin the joint. Furthermore, some joints require greater tensile strength and stiffness than rivets can provide. Bolts and screws are two types of fastening devices which give the required security of attachment and rigidity. Generally, bolts are used where great strength is required, and screws are used where strength is not the deciding factor. Bolts

Sealant Base	Accelerator (Catalyst)	Mixing Ratio by Weight	Application Life (Work)	Storage (Shelf) Life After Mixing	Storage (Shelf) Life Unmixed	Temperature Range	Application and Limitations
EC-801 (black) MIL-S-7502A Class B-2	EC-807	12 parts of EC-807 to 100 parts of EC-801	2–4 hours	5 days at –20 °F after flash freeze at –65 °F	6 months	–65 °F to 200 °F	Faying surfaces, fillet seals, and packing gaps
EC-800 (red)	None	Use as is	8–12 hours	Not applicable	6–9 months	–65 °F to 200 °F	Coating rivet
EC-612 P (pink) MIL-P-20628	None	Use as is	Indefinite non-drying	Not applicable	6–9 months	–40 °F to 200 °F	Packing voids up to 1/4 inch
PR-1302HT (red) MIL-S-8784	PR-1302HT-A	10 parts of PR-1302HT-A to 100 parts of PR-1302HT	2–4 hours	5 days at –20 °F after flash freeze at –65 °F	6 months	–65 °F to 200 °F	Sealing access door gaskets
PR-727 potting compound MIL-S-8516B	PR-727A	12 parts of PR-727A to 100 parts of PR-727	1½ hours minimum	5 days at –20 °F after flash freeze at –65 °F	6 months	–65 °F to 200 °F	Potting electrical connections and bulkhead seals
HT-3 (greygreen)	None	Use as is	Solvent release, sets up in 2–4 hours	Not applicable	6–9 months	–60 °F to 850 °F	Sealing hot air ducts passing through bulkheads
EC-776 (clear amber) MIL-S-4383B	None	Use as is	8–12 hours	Not applicable	Indefinite in airtight containers	–65 °F to 250 °F	Top coating

Figure 5-18. General sealant information.

and screws are similar in many ways. They are both used for fastening or holding, and each has a head on one end and screw threads on the other. Regardless of these similarities, there are several distinct differences between the two types of fasteners. The threaded end of a bolt is always blunt while that of a screw may be either blunt or pointed.

The threaded end of a bolt usually has a nut screwed onto it to complete the assembly. The threaded end of a screw may fit into a female receptacle, or it may fit directly into the material being secured. A bolt has a fairly short threaded section and a comparatively long grip length or unthreaded portion; whereas a screw has a longer threaded section and may have no clearly defined grip length. A bolt assembly is generally tightened by turning the nut on the bolt; the head of the bolt

may or may not be designed for turning. A screw is always tightened by turning its head.

When it becomes necessary to replace aircraft fasteners, a duplicate of the original fastener should be used if at all possible. If duplicate fasteners are not available, extreme care and caution must be used in selecting substitutes.

Classification of Threads

Aircraft bolts, screws, and nuts are threaded in the NC (American National Coarse) thread series, the NF (American National Fine) thread series, the UNC (American Standard Unified Coarse) thread series, or the UNF (American Standard Unified Fine) thread series. There is one difference between the American National series and the American Standard Unified

series that should be pointed out. In the 1-inch diameter size, the NF thread specifies 14 threads per inch (1-14 NF), while the UNF thread specifies 12 threads per inch (1-12 UNF). Both types of threads are designated by the number of times the incline (threads) rotates around a 1-inch length of a given diameter bolt or screw. For example, a 4-28 thread indicates that a $\frac{1}{4}$ -inch ($\frac{4}{16}$ inch) diameter bolt has 28 threads in 1 inch of its threaded length.

Threads are also designated by Class of fit. The Class of a thread indicates the tolerance allowed in manufacturing. Class 1 is a loose fit, Class 2 is a free fit, Class 3 is a medium fit, and Class 4 is a close fit. Aircraft bolts are almost always manufactured in the Class 3, medium fit.

A Class 4 fit requires a wrench to turn the nut onto a bolt, whereas a Class 1 fit can easily be turned with the fingers. Generally, aircraft screws are manufactured with a Class 2 thread fit for ease of assembly.

Bolts and nuts are also produced with right-hand and left-hand threads. A right-hand thread tightens when turned clockwise; a left-hand thread tightens when turned counterclockwise.

Aircraft Bolts

Aircraft bolts are fabricated from cadmium- or zinc-plated corrosion resistant steel, unplated corrosion resistant steel, or anodized aluminum alloys. Most bolts used in aircraft structures are either general purpose, AN bolts, or NAS internal wrenching or close tolerance bolts, or MS bolts. In certain cases, aircraft manufacturers make bolts of different dimensions or greater strength than the standard types. Such bolts are made for a particular application, and it is of extreme importance to use like bolts in replacement. Special bolts are usually identified by the letter “S” stamped on the head.

AN bolts come in three head styles—hex head, clevis, and eyebolt. [Figure 5-19] NAS bolts are available in hex head, internal wrenching, and countersunk head styles. MS bolts come in hex head and internal wrenching styles.

General Purpose Bolts

The hex head aircraft bolt (AN-3 through AN-20) is an all-purpose structural bolt used for general applications involving tension or shear loads where a light drive fit is permissible (0.006-inch clearance for a $\frac{5}{8}$ -inch hole, and other sizes in proportion).

Alloy steel bolts smaller than No. 10-32 and aluminum alloy bolts smaller than $\frac{1}{4}$ inch in diameter are not used in primary structures. Aluminum alloy bolts and nuts are not used where they will be repeatedly removed for purposes of maintenance and inspection. Aluminum alloy nuts may be used with cadmium-plated steel bolts loaded in shear on land airplanes, but are not used on seaplanes due to the increased possibility of dissimilar metal corrosion.

The AN-73 drilled head bolt is similar to the standard hex bolt, but has a deeper head which is drilled to receive wire for safetying. The AN-3 and the AN-73 series bolts are interchangeable, for all practical purposes, from the standpoint of tension and shear strengths.

Close Tolerance Bolts

This type of bolt is machined more accurately than the general purpose bolt. Close tolerance bolts may be hex headed (AN-173 through AN-186) or have a 100° countersunk head (NAS-80 through NAS-86). They are used in applications where a tight drive fit is required. (The bolt will move into position only when struck with a 12- to 14-ounce hammer.)

Internal Wrenching Bolts

These bolts, (MS-20004 through MS-20024 or NAS-495) are fabricated from high-strength steel and are suitable for use in both tension and shear applications. When they are used in steel parts, the bolt hole must be slightly countersunk to seat the large corner radius of the shank at the head. In Dural material, a special heat-treated washer must be used to provide an adequate bearing surface for the head. The head of the internal wrenching bolt is recessed to allow the insertion of an internal wrench when installing or removing the bolt. Special high-strength nuts are used on these bolts. Replace an internal wrenching bolt with another internal wrenching bolt. Standard AN hex head bolts and washers cannot be substituted for them as they do not have the required strength.

Identification and Coding

Bolts are manufactured in many shapes and varieties. A clear-cut method of classification is difficult. Bolts can be identified by the shape of the head, method of securing, material used in fabrication, or the expected usage.

AN-type aircraft bolts can be identified by the code markings on the bolt heads. The markings generally denote the bolt manufacturer, the material of which the bolt is made, and whether the bolt is a standard AN-type or a special purpose bolt. AN standard steel

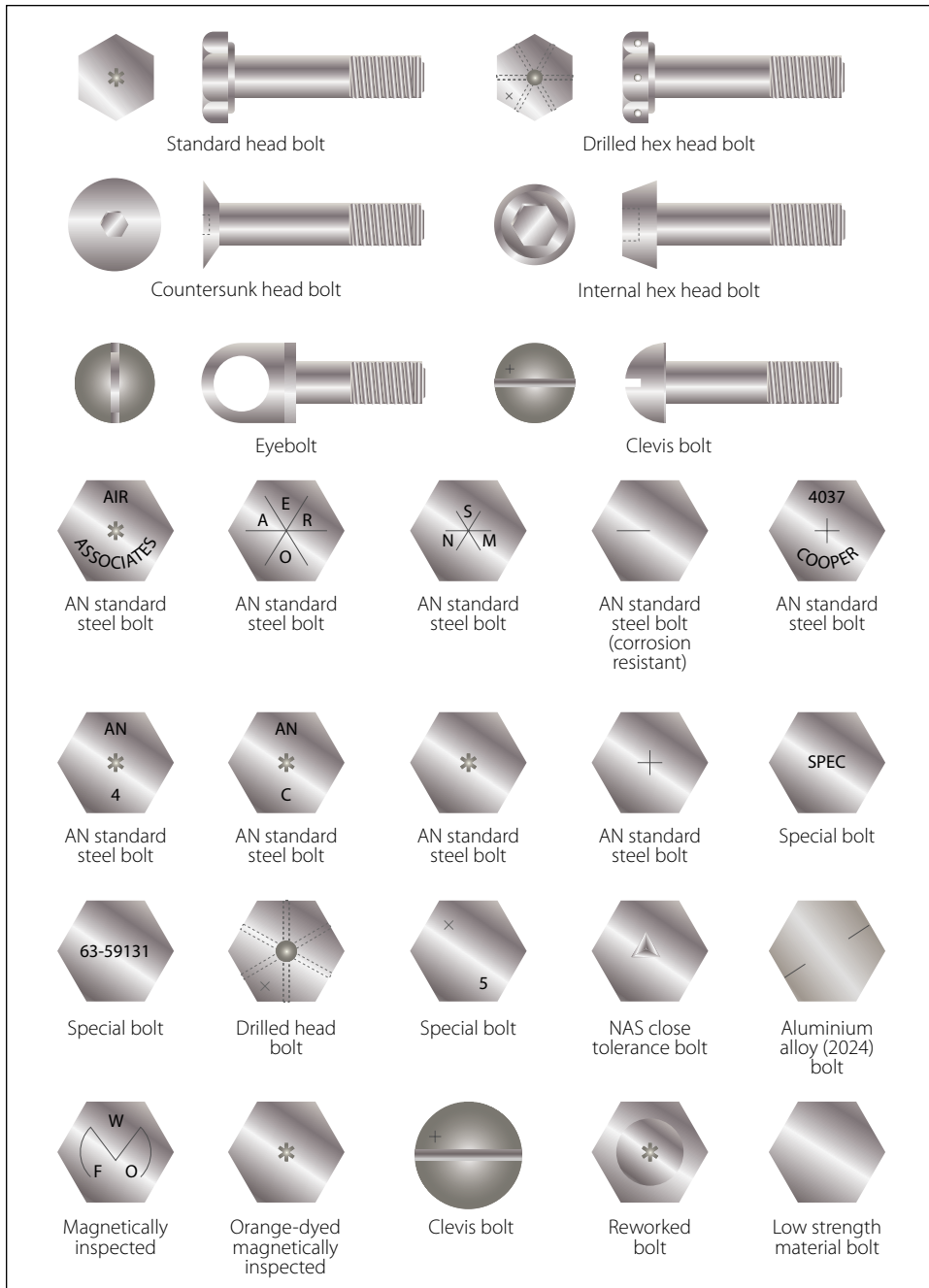

Figure 5-19. Aircraft bolt identification.

bolts are marked with either a raised dash or asterisk; corrosion resistant steel is indicated by a single raised dash; and AN aluminum alloy bolts are marked with two raised dashes. Additional information, such as bolt diameter, bolt length, and grip length may be obtained from the bolt part number.

For example, in the bolt part number AN3DD5A, the “AN” designates that it is an Air Force-Navy Standard bolt, the “3” indicates the diameter in sixteenths of an inch ($\frac{3}{16}$), the “DD” indicates the material is 2024 aluminum alloy. The letter “C” in place of the “DD” would

indicate corrosion resistant steel, and the absence of the letters would indicate cadmium plated steel. The “5” indicates the length in eighths of an inch ($\frac{5}{8}$), and the “A” indicates that the shank is undrilled. If the letter “H” preceded the “5” in addition to the “A” following it, the head would be drilled for safetying.

Close tolerance NAS bolts are marked with either a raised or recessed triangle. The material markings for NAS bolts are the same as for AN bolts, except that they may be either raised or recessed. Bolts inspected magnetically (Magnaflux) or by fluorescent means

(Zyglo) are identified by means of colored lacquer, or a head marking of a distinctive type.

Special-Purpose Bolts

Bolts designed for a particular application or use are classified as special-purpose bolts. Clevis bolts, eyebolts, Jo-bolts, and lockbolts are special-purpose bolts.

Clevis Bolts

The head of a clevis bolt is round and is either slotted to receive a common screwdriver or recessed to receive a crosspoint screwdriver. This type of bolt is used only where shear loads occur and never in tension. It is often inserted as a mechanical pin in a control system.

Eyebolt

This type of special purpose bolt is used where external tension loads are to be applied. The eyebolt is designed for the attachment of such devices as the fork of a turnbuckle, a clevis, or a cable shackle. The threaded end may or may not be drilled for safetying.

Jo-Bolt

Jo-bolt is a trade name for an internally threaded three-piece rivet. The Jo-bolt consists of three parts—a threaded steel alloy bolt, a threaded steel nut, and an expandable stainless steel sleeve. The parts are factory preassembled. As the Jo-bolt is installed, the bolt is turned while the nut is held. This causes the sleeve to expand over the end of the nut, forming the blind head and clamping against the work. When driving is complete, a portion of the bolt breaks off. The high shear and tensile strength of the Jo-bolt makes it suitable for use in cases of high stresses where some of the other blind fasteners would not be practical. Jo-bolts are often a part of the permanent structure of late model aircraft. They are used in areas which are not often subjected to replacement or servicing. (Because it is a three-part fastener, it should not be used where any part, in becoming loose, could be drawn into the engine air intake.) Other advantages of using Jo-bolts are their excellent resistance to vibration, weight saving, and fast installation by one person.

Presently, Jo-bolts are available in four diameters: The 200 series, approximately $\frac{3}{16}$ inch in diameter; the 260 series, approximately $\frac{1}{4}$ inch in diameter; the 312 series, approximately $\frac{5}{16}$ inch in diameter; and the 375 series, approximately $\frac{3}{8}$ inch in diameter. Jo-bolts are available in three head styles which are: F (flush), P (hex head), and FA (flush millable).

Lockbolts

Lockbolts are used to attach two materials permanently. They are lightweight and are equal in strength to standard bolts. Lockbolts are manufactured by several companies and conform to Military Standards. Military Standards specify the size of a lockbolt's head in relation to the shank diameter, plus the alloy used in its construction. The only drawback to lockbolt installations is that they are not easily removable compared to nuts and bolts.

The lockbolt combines the features of a high-strength bolt and rivet, but it has advantages over both. The lockbolt is generally used in wing splice fittings, landing gear fittings, fuel cell fittings, longerons, beams, skin splice plates, and other major structural attachments. It is more easily and quickly installed than the conventional rivet or bolt and eliminates the use of lockwashers, cotter pins, and special nuts. Like the rivet, the lockbolt requires a pneumatic hammer or "pull gun" for installation; when installed, it is rigidly and permanently locked in place. Three types of lockbolts are commonly used: the pull type, the stump type, and the blind type. [Figure 5-20]

Pull type. Pull-type lockbolts are used mainly in aircraft primary and secondary structures. They are installed

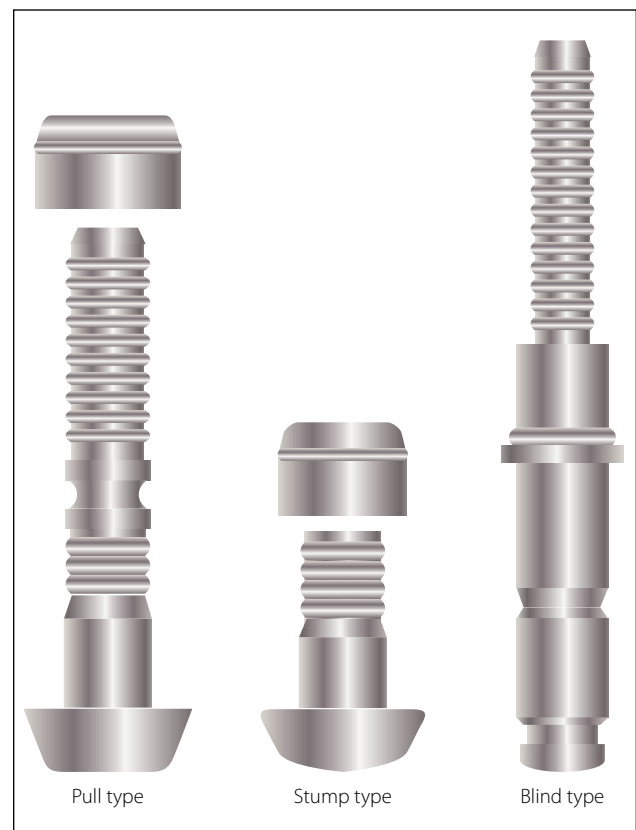

Figure 5-20. Lockbolt types.

very rapidly and have approximately one-half the weight of equivalent AN steel bolts and nuts. A special pneumatic “pull gun” is required to install this type of lockbolt. Installation can be accomplished by one person since bucking is not required.

Stump type. Stump-type lockbolts, although they do not have the extended stem with pull grooves, are companion fasteners to pull-type lockbolts. They are used primarily where clearance will not permit installation of the pull-type lockbolt. A standard pneumatic riveting hammer (with a hammer set attached for swaging the collar into the pin locking grooves) and a bucking bar are tools necessary for the installation of stump-type lockbolts.

Blind type. Blind-type lockbolts come as complete units or assemblies. They have exceptional strength and sheet pull-together characteristics. Blind lockbolts are used where only one side of the work is accessible and, generally, where it is difficult to drive a conventional rivet. This type of lockbolt is installed in the same manner as the pull-type lockbolt.

Common features. Common features of the three types of lockbolts are the annular locking grooves on the pin and the locking collar which is swaged into the pin’s lock grooves to lock the pin in tension. The pins of the pull- and blind-type lockbolts are extended for pull installation. The extension is provided with pulling grooves and a tension breakoff groove.

Composition. The pins of pull- and stump-type lockbolts are made of heat-treated alloy steel or high strength aluminum alloy. Companion collars are made of aluminum alloy or mild steel. The blind lockbolt consists of a heat-treated alloy steel pin, blind sleeve and filler sleeve, mild steel collar, and carbon steel washer.

Substitution. Alloy steel lockbolts may be used to replace steel high-shear rivets, solid steel rivets, or AN bolts of the same diameter and head type. Aluminum alloy lockbolts may be used to replace solid aluminum alloy rivets of the same diameter and head type. Steel and aluminum alloy lockbolts may also be used to replace steel and 2024T aluminum alloy bolts, respectively, of the same diameter. Blind lockbolts may be used to replace solid aluminum alloy rivets, stainless steel rivets, or all blind rivets of the same diameter.

Numbering system. The numbering systems for the various types of lockbolts are explained by the breakouts in Figure 5-23.

Grip No.	Grip Range		Grip No.	Grip Range	
	Min.	Max.		Min.	Max.
1	.031	.094	17	1.031	1.094
2	.094	.156	18	1.094	1.156
3	.156	.219	19	1.156	1.219
4	.219	.281	20	1.219	1.281
5	.281	.344	21	1.281	1.344
6	.344	.406	22	1.344	1.406
7	.406	.469	23	1.406	1.469
8	.469	.531	24	1.469	1.531
9	.531	.594	25	1.531	1.594
10	.594	.656	26	1.594	1.656
11	.656	.718	27	1.656	1.718
12	.718	.781	28	1.718	1.781
13	.781	.843	29	1.781	1.843
14	.843	.906	30	1.843	1.906
15	.906	.968	31	1.906	1.968
16	.968	1.031	32	1.968	2.031
			33	2.031	2.094

Figure 5-21. Pull- and stump-type lockbolt grip ranges.

Grip Range. To determine the bolt grip range required for any application, measure the thickness of the material with a hook scale inserted through the hole. Once this measurement is determined, select the correct grip range by referring to the charts provided by the rivet manufacturer. Examples of grip range charts are shown in Figures 5-21 and 5-24.

When installed, the lockbolt collar should be swaged substantially throughout the complete length of the collar. The tolerance of the broken end of the pin relative to the top of the collar must be within the dimensions given in Figure 5-22.

Pin diameter	Tolerance	
	Below	Above
$\frac{3}{16}$	0.079	to 0.032
$\frac{1}{4}$	0.079	to 0.050
$\frac{5}{16}$	0.079	to 0.050
$\frac{3}{8}$	0.079	to 0.060

Figure 5-22. Pin tolerance ranges.

<p>Pull-type lockbolt ALPP H T 8 8</p> <p>ALPP Head type ACT509 = close tolerance AN-509 C-sink head ALPP = pan head ALPB = brazier head ALP509 = standard AN-509 C-sink head ALP426 = standard AN-426 C-sink head</p> <p>H Class fit H = hole filling (interference fit) N = non-hole filling (clearance fit)</p> <p>T Pin Materials E = 75S-T6 aluminum alloy T = heat-treated alloy steel</p> <p>8 Body diameter in 32nds of an inch</p> <p>8 Grip length in 16ths of an inch</p> <p>Blind-type lockbolt BL 8 4</p> <p>BL Blind Lockbolt</p> <p>8 Diameter in 32nds of an inch</p> <p>4 Grip length in 16ths of an inch, $\pm \frac{1}{32}$ inch</p>	<p>Lockbolt collar LC C C</p> <p>LC Lockbolt collar</p> <p>C Material C = 24ST aluminum alloy (green color). Use with heat-treated alloy lockbolts only. F = 61ST aluminum alloy (plain color). Use with 75ST aluminum alloy lockbolts only. R = mild steel (cadmium plated). Use with heat-treated alloy steel lockbolts for high temperature applications only.</p> <p>C Diameter of a pin in 32nds of an inch</p> <p>Stump-type lockbolt ALSF E 8 8</p> <p>ALSF Head type ASCT509 = close tolerance AN-509 C-sink head ALSF = flathead type. ALS509 = standard AN-509 C-sink head ALS426 = standard AN-426 C-sink head</p> <p>E Pin materials E = 75S-T6 aluminum alloy T = heat-treated alloy steel</p> <p>8 Body diameter in 32nds of an inch</p> <p>8 Grip length in 16ths of an inch</p>
--	--

Figure 5-23. Lockbolt numbering system.

When removal of a lockbolt becomes necessary, remove the collar by splitting it axially with a sharp, cold chisel. Be careful not to break out or deform the hole. The use of a backup bar on the opposite side of the collar being split is recommended. The pin may then be driven out with a drift punch.

Aircraft Nuts

Aircraft nuts are made in a variety of shapes and sizes. They are made of cadmium plated carbon steel, stainless steel, or anodized 2024T aluminum alloy, and may be obtained with either right- or left-hand threads. No identifying marking or lettering appears on nuts. They can be identified only by the characteristic metallic luster or color of the aluminum, brass, or the insert when the nut is of the self-locking type. They can be further identified by their construction.

Aircraft nuts can be divided into two general groups: non-self-locking and self-locking nuts. Non-self-locking nuts are those that must be safetied by external locking devices, such as cotter pins, safety wire, or locknuts. Self-locking nuts contain the locking feature as an integral part.

Non-Self-Locking Nuts

Most of the familiar types of nuts, including the plain nut, the castle nut, the castellated shear nut, the plain

1/4-inch Diameter			5/16-inch Diameter		
Grip No.	Grip Range		Grip No.	Grip Range	
	Min.	Max.		Min.	Max.
1	.031	.094	2	.094	.156
2	.094	.156	3	.156	.219
3	.156	.219	4	.219	.281
4	.219	.281	5	.281	.344
5	.281	.344	6	.344	.406
6	.344	.406	7	.406	.469
7	.406	.469	8	.469	.531
8	.469	.531	9	.531	.594
9	.531	.594	10	.594	.656
10	.594	.656	11	.656	.718
11	.656	.718	12	.718	.781
12	.718	.781	13	.781	.843
13	.781	.843	14	.843	.906
14	.843	.906	15	.906	.968
15	.906	.968	16	.968	1.031
16	.968	1.031	17	1.031	1.094
17	1.031	1.094	18	1.094	1.156
18	1.094	1.156	19	1.156	1.219
19	1.156	1.219	20	1.219	1.281
20	1.219	1.281	21	1.281	1.343
21	1.281	1.343	22	1.343	1.406
22	1.344	1.406	23	1.406	1.469
23	1.406	1.469	24	1.460	1.531
24	1.469	1.531			
25	1.531	1.594			

Figure 5-24. Blind-type lockbolt grip ranges.

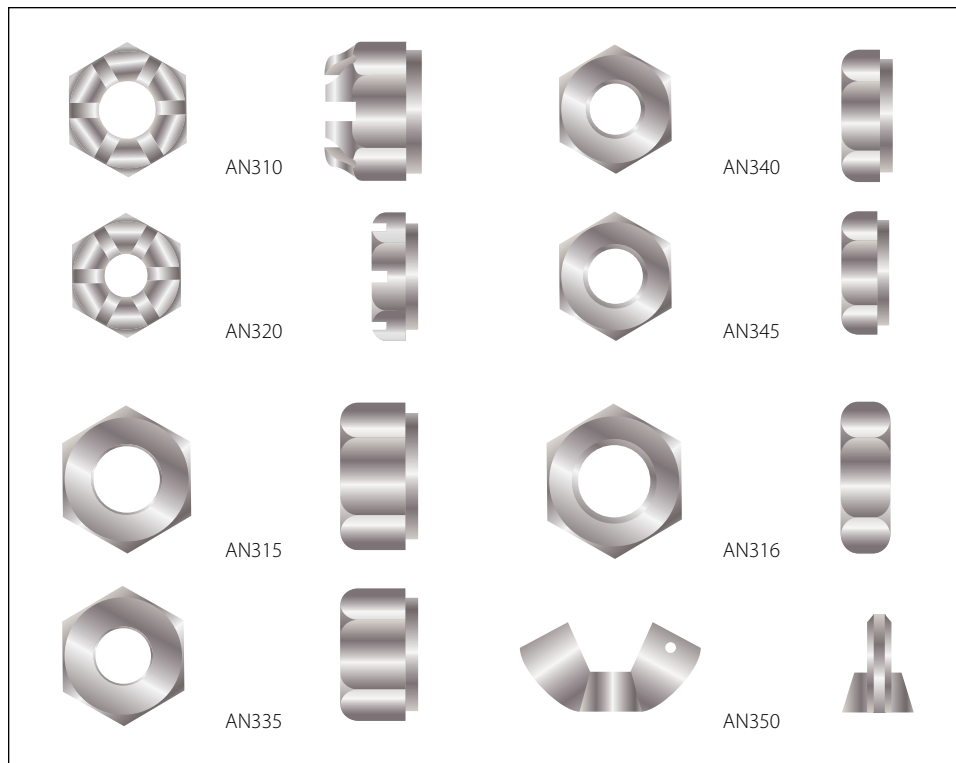

Figure 5-25. Non-self-locking nuts.

hex nut, the light hex nut, and the plain checknut are the non-self-locking type. [Figure 5-25]

The castle nut, AN310, is used with drilled shank AN hex head bolts, clevis bolts, eyebolts, drilled head bolts, or studs. It is fairly rugged and can withstand large tensional loads. Slots (called castellations) in the nut are designed to accommodate a cotter pin or lockwire for safety.

The castellated shear nut, AN320, is designed for use with devices (such as drilled clevis bolts and threaded taper pins) which are normally subjected to shearing stress only. Like the castle nut, it is castellated for safetying. Note, however, that the nut is not as deep or as strong as the castle nut; also that the castellations are not as deep as those in the castle nut.

The plain hex nut, AN315 and AN335 (fine and coarse thread), is of rugged construction. This makes it suitable for carrying large tensional loads. However, since it requires an auxiliary locking device, such as a checknut or lockwasher, its use on aircraft structures is somewhat limited.

The light hex nut, AN340 and AN345 (fine and coarse thread), is a much lighter nut than the plain hex nut and must be locked by an auxiliary device. It is used for miscellaneous light tension requirements.

The plain checknut, AN316, is employed as a locking device for plain nuts, set screws, threaded rod ends, and other devices.

The wing nut, AN350, is intended for use where the desired tightness can be obtained with the fingers and where the assembly is frequently removed.

Self-Locking Nuts

As their name implies, self-locking nuts need no auxiliary means of safetying but have a safetying feature included as an integral part of their construction. Many types of self-locking nuts have been designed and their use has become quite widespread. Common applications are: (1) attachment of antifriction bearings and control pulleys; (2) attachment of accessories, anchor nuts around inspection holes and small tank installation openings; and (3) attachment of rocker box covers and exhaust stacks. Self-locking nuts are acceptable for use on certificated aircraft subject to the restrictions of the manufacturer.

Self-locking nuts are used on aircraft to provide tight connections which will not shake loose under severe vibration. Do not use self-locking nuts at joints which subject either the nut or bolt to rotation. They may be used with antifriction bearings and control pulleys, provided the inner race of the bearing is clamped to the supporting structure by the nut and bolt. Plates

must be attached to the structure in a positive manner to eliminate rotation or misalignment when tightening the bolts or screws.

The two general types of self-locking nuts currently in use are the all-metal type and the fiber lock type. For the sake of simplicity, only three typical kinds of self-locking nuts are considered in this handbook: the Boots self-locking and the stainless steel self-locking nuts, representing the all-metal types; and the elastic stop nut, representing the fiber insert type.

Boots Self-Locking Nut

The Boots self-locking nut is of one piece, all-metal construction, designed to hold tight in spite of severe vibration. Note in Figure 5-26 that it has two sections and is essentially two nuts in one, a locking nut and a load-carrying nut. The two sections are connected with a spring which is an integral part of the nut.

The spring keeps the locking and load-carrying sections such a distance apart that the two sets of threads are out of phase; that is, so spaced that a bolt which has been screwed through the load carrying section must push the locking section outward against the force of the spring to engage the threads of the locking section properly.

Thus, the spring, through the medium of the locking section, exerts a constant locking force on the bolt in the same direction as a force that would tighten the nut. In this nut, the load-carrying section has the thread strength of a standard nut of comparable size, while the locking section presses against the threads of the bolt and locks the nut firmly in position. Only a wrench applied to the nut will loosen it. The nut can be removed and reused without impairing its efficiency.

Boots self-locking nuts are made with three different spring styles and in various shapes and sizes. The wing type, which is the most common, ranges in size for No. 6 up to 1/4 inch, the Rol-top ranges from 1/4 inch to 1/6 inch, and the bellows type ranges in size from No. 8 up to 3/8 inch. Wing-type nuts are made of anodized aluminum alloy, cadmium-plated carbon steel, or stainless steel. The Rol-top nut is cadmium-plated steel, and the bellows type is made of aluminum alloy only.

Stainless Steel Self-Locking Nut

The stainless steel self-locking nut may be spun on and off with the fingers, as its locking action takes place only when the nut is seated against a solid surface and tightened. The nut consists of two parts: a case with a beveled locking shoulder and key, and a threaded insert with a locking shoulder and slotted keyway. Until the

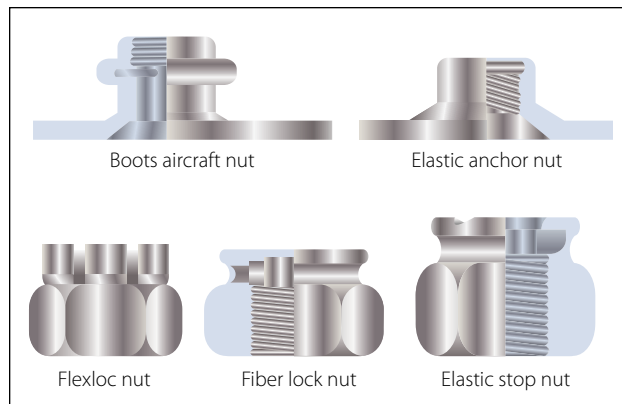

Figure 5-26. Self-locking nuts.

nut is tightened, it spins on the bolt easily because the threaded insert is the proper size for the bolt. However, when the nut is seated against a solid surface and tightened, the locking shoulder of the insert is pulled downward and wedged against the locking shoulder of the case. This action compresses the threaded insert and causes it to clench the bolt tightly. The cross-sectional view in Figure 5-27 shows how the key of the case fits into the slotted keyway of the insert so that when the case is turned, the threaded insert is turned with it. Note that the slot is wider than the key. This permits the slot to be narrowed and the insert to be compressed when the nut is tightened.

Elastic Stop Nut

The elastic stop nut is a standard nut with the height increased to accommodate a fiber locking collar. This

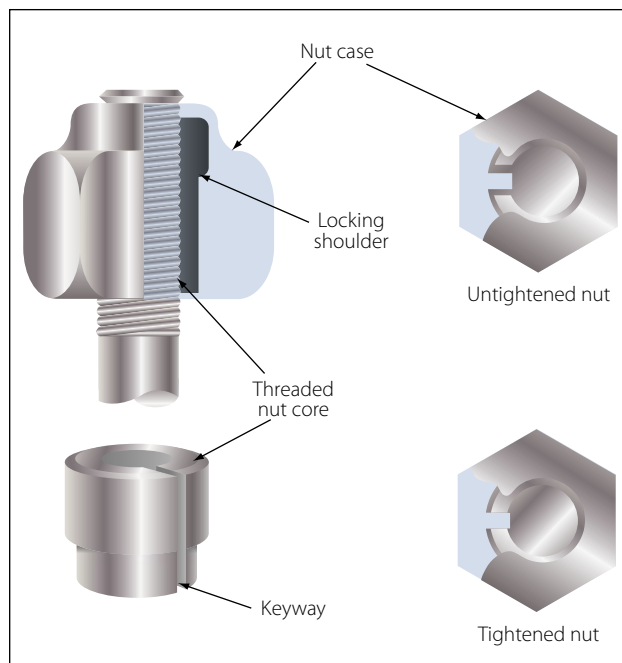

Figure 5-27. Stainless steel self-locking nut.

fiber collar is very tough and durable and is unaffected by immersion in hot or cold water or ordinary solvents, such as ether, carbon tetrachloride, oils, and gasoline. It will not damage bolt threads or plating.

As shown in Figure 5-28, the fiber locking collar is not threaded and its inside diameter is smaller than the largest diameter of the threaded portion or the outside diameter of a corresponding bolt. When the nut is screwed onto a bolt, it acts as an ordinary nut until the bolt reaches the fiber collar. When the bolt is screwed into the fiber collar, however, friction (or drag) causes the fiber to be pushed upward. This creates a heavy downward pressure on the load carrying part and automatically throws the load carrying sides of the nut and bolt threads into positive contact. After the bolt has been forced all the way through the fiber collar, the downward pressure remains constant. This pressure locks and holds the nut securely in place even under severe vibration.

Nearly all elastic stop nuts are steel or aluminum alloy. However, such nuts are available in practically any kind of metal. Aluminum alloy elastic stop nuts are supplied with an anodized finish. Steel nuts are cadmium plated.

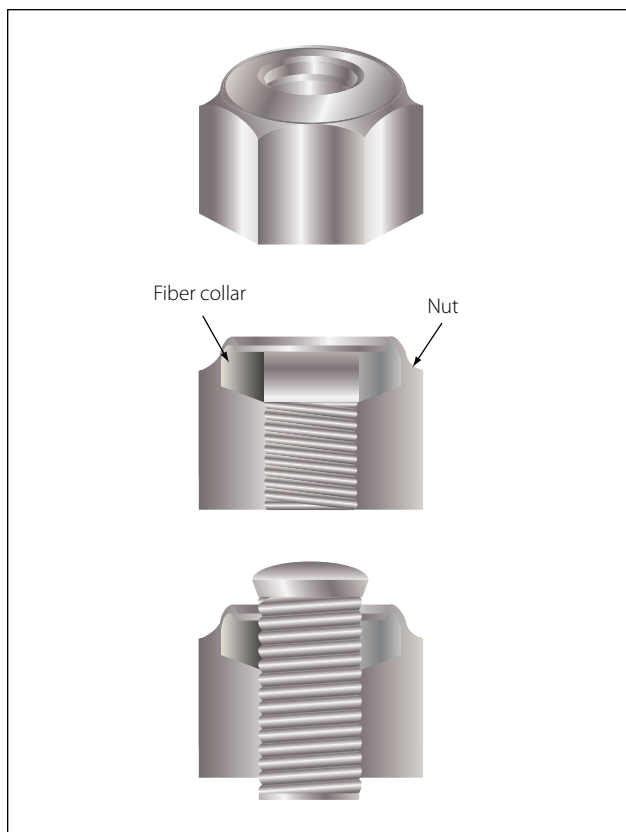

Figure 5-28. Elastic stop nut.

Normally, elastic stop nuts can be used many times with complete safety and without detriment to their locking efficiency. When reusing elastic stop nuts, be sure the fiber has not lost its locking friction or become brittle. If a nut can be turned with the fingers, replace it.

After the nut has been tightened, make sure the rounded or chamfered end of the bolts, studs, or screws extends at least the full round or chamfer through the nut. Flat end bolts, studs, or screws should extend at least $\frac{1}{32}$ inch through the nut. Bolts of $\frac{5}{16}$ -inch diameter and over with cotter pin holes may be used with self-locking nuts, but only if free from burrs around the holes. Bolts with damaged threads and rough ends are not acceptable. Do not tap the fiber locking insert. The self-locking action of the elastic stop nut is the result of having the bolt threads impress themselves into the untapped fiber.

Do not install elastic stop nuts in places where the temperature is higher than 250 °F, because the effectiveness of the self-locking action is reduced beyond this point. Self-locking nuts may be used on aircraft engines and accessories when their use is specified by the engine manufacturer.

Self-locking nut bases are made in a number of forms and materials for riveting and welding to aircraft structure or parts. [Figure 5-29] Certain applications require the installation of self-locking nuts in channels, an arrangement which permits the attachment of many nuts with only a few rivets. These channels are track-like bases with regularly spaced nuts which are either removable or nonremovable. The removable type carries a floating nut, which can be snapped in or out of the channel, thus making possible the easy removal of damaged nuts. Nuts, such as the clinch-type and spline-type, which depend on friction for their anchorage, are not acceptable for use in aircraft structures.

Sheet Spring Nuts

Sheet spring nuts, such as speed nuts, are used with standard and sheet metal self-tapping screws in non-structural locations. They find various uses in supporting line clamps, conduit clamps, electrical equipment, access doors, and the like, and are available in several types. Speed nuts are made from spring steel and are arched prior to tightening. This arched spring lock prevents the screw from working loose. These nuts should be used only where originally used in the fabrication of the aircraft.

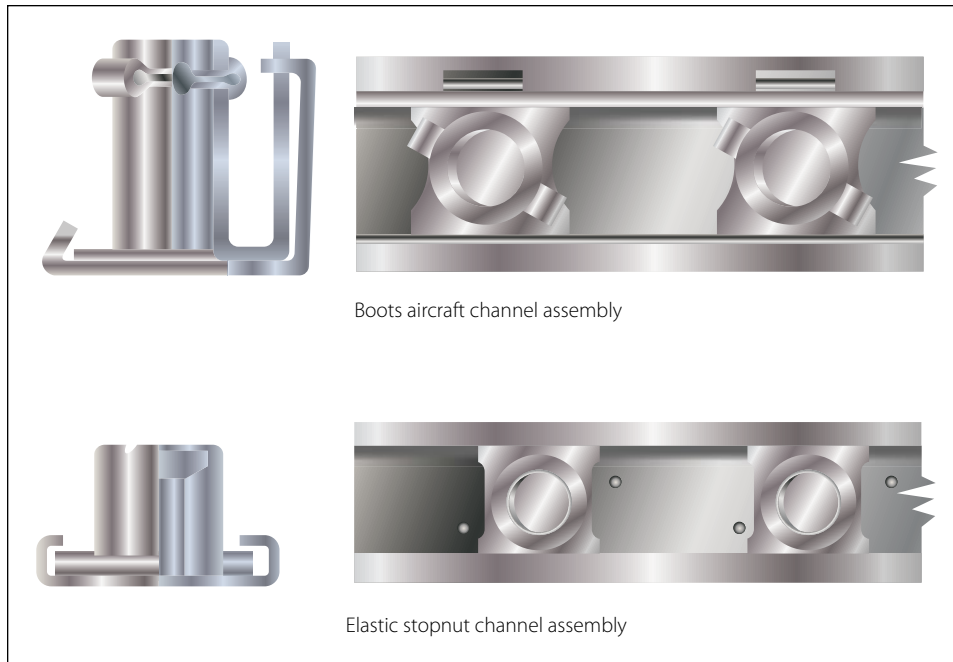

Figure 5-29. Self-locking nut bases.

Internal and External Wrenching Nuts

Two commercial types of high strength internal or external wrenching nuts are available; they are the internal and external wrenching elastic stop nut and the *Unbrako* internal and external wrenching nut. Both are of the self-locking type, are heat treated, and are capable of carrying high strength bolt tension loads.

Identification and Coding

Part numbers designate the type of nut. The common types and their respective part numbers are: Plain, AN315 and AN335; castle AN310; plain check, AN316; light hex, AN340 and AN345; and castellated shear, AN320. The patented self-locking types are assigned part numbers ranging from MS20363 through MS20367. The Boots, the Flexloc, the fiber locknut, the elastic stop nut, and the self-locking nut belong to this group. Part number AN350 is assigned to the wing nut.

Letters and digits following the part number indicate such items as material, size, threads per inch, and whether the thread is right or left hand. The letter “B” following the part number indicates the nut material to be brass, a “D” indicates 2017-T aluminum alloy, a “DD” indicates 2024-T aluminum alloy, a “C” indicates stainless steel, and a dash in place of a letter indicates cadmium-plated carbon steel.

The digit (or two digits) following the dash or the material code letter is the dash number of the nut, and it indicates the size of the shank and threads per inch

of the bolt on which the nut will fit. The dash number corresponds to the first figure appearing in the part number coding of general purpose bolts. A dash and the number 3, for example, indicates that the nut will fit an AN3 bolt (10-32); a dash and the number 4 means it will fit an AN4 bolt (1/4-28); a dash and the number 5, an AN5 bolt (5/16-24); and so on.

The code numbers for self-locking nuts end in three or four digit numbers. The last two digits refer to threads per inch, and the one or two preceding digits stand for the nut size in 16ths of an inch.

Some other common nuts and their code numbers are:

Code Number AN310D5R:

AN310 = aircraft castle nut

D = 2024-T aluminum alloy

5 = $\frac{5}{16}$ inch diameter

R = right-hand thread (usually 24 threads per inch)

Code Number AN320-10:

AN320 = aircraft castellated shear nut, cadmium-plated carbon steel

10 = $\frac{5}{8}$ inch diameter, 18 threads per inch
(this nut is usually right-hand thread)

Code Number AN350B1032:

AN350 = aircraft wing nut

B = brass

10 = number 10 bolt

32 = threads per inch

Aircraft Washers

Aircraft washers used in airframe repair are either plain, lock, or special type washers.

Plain Washers

Plain washers [Figure 5-30], both the AN960 and AN970, are used under hex nuts. They provide a smooth bearing surface and act as a shim in obtaining correct grip length for a bolt and nut assembly. They are used to adjust the position of castellated nuts in respect to drilled cotter pin holes in bolts. Use plain washers under lockwashers to prevent damage to the surface material.

Aluminum and aluminum alloy washers may be used under bolt heads or nuts on aluminum alloy or magnesium structures where corrosion caused by dissimilar metals is a factor. When used in this manner, any electric current flow will be between the washer and the steel bolt. However, it is common practice to use a cadmium plated steel washer under a nut bearing directly against a structure as this washer will resist the cutting action of a nut better than an aluminum alloy washer.

The AN970 steel washer provides a greater bearing area than the AN960 washer and is used on wooden

structures under both the head and the nut of a bolt to prevent crushing the surface.

Lockwashers

Lockwashers, both the AN935 and AN936, are used with machine screws or bolts where the self-locking or castellated-type nut is not appropriate. The spring action of the washer (AN935) provides enough friction to prevent loosening of the nut from vibration. [Figure 5-30]

Lockwashers should never be used under the following conditions:

- With fasteners to primary or secondary structures
- With fasteners on any part of the aircraft where failure might result in damage or danger to the aircraft or personnel
- Where failure would permit the opening of a joint to the airflow
- Where the screw is subject to frequent removal
- Where the washers are exposed to the airflow
- Where the washers are subject to corrosive conditions
- Where the washer is against soft material without a plain washer underneath to prevent gouging the surface

Shakeproof Lockwashers

Shakeproof lockwashers are round washers designed with tabs or lips that are bent upward across the sides of a hex nut or bolt to lock the nut in place. There are various methods of securing the lockwasher to prevent it from turning, such as an external tab bent downward 90° into a small hole in the face of the unit, or an internal tab which fits a keyed bolt.

Shakeproof lockwashers can withstand higher heat than other methods of safetying and can be used under high vibration conditions safely. They should be used only once because the tabs tend to break when bent a second time.

Special Washers

The ball socket and seat washers, AC950 and AC955, are special washers used where a bolt is installed at an angle to a surface, or where perfect alignment with a surface is required. These washers are used together. [Figure 5-30]

The NAS143 and MS20002 washers are used for internal wrenching bolts of the NAS144 through NAS158

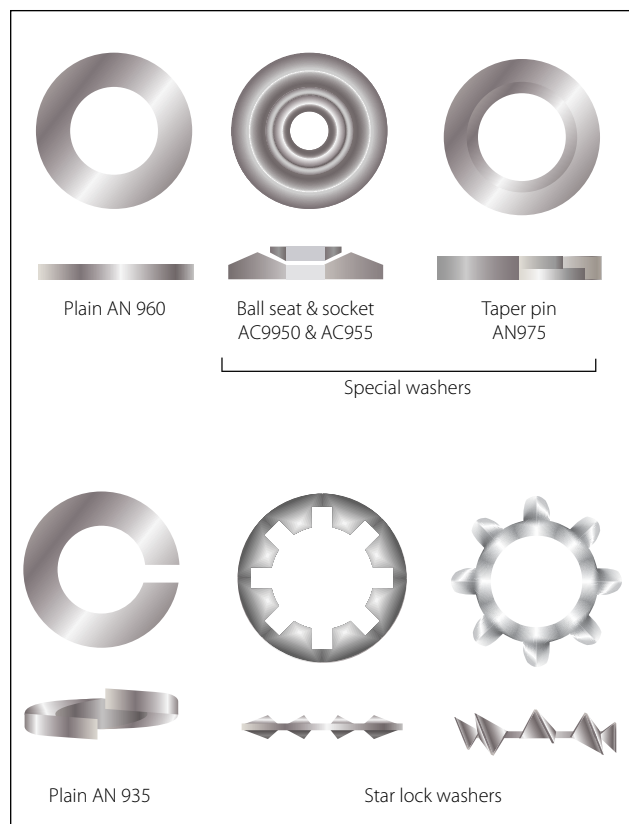

Figure 5-30. Various types of washers.

series. This washer is either plain or countersunk. The countersunk washer (designated as NAS143C and MS20002C) is used to seat the bolt head shank radius, and the plain washer is used under the nut.

Installation of Nuts, Washers, and Bolts

Bolt and Hole Sizes

Slight clearances in bolt holes are permissible wherever bolts are used in tension and are not subject to reversal of load. A few of the applications in which clearance of holes may be permitted are in pulley brackets, conduit boxes, lining trim, and miscellaneous supports and brackets.

Bolt holes are to be normal to the surface involved to provide full bearing surface for the bolt head and nut, and must not be oversized or elongated. A bolt in such a hole will carry none of its shear load until parts have yielded or deformed enough to allow the bearing surface of the oversized hole to contact the bolt. In this respect, remember that bolts do not become swaged to fill up the holes as do rivets.

In cases of oversized or elongated holes in critical members, obtain advice from the aircraft or engine manufacturer before drilling or reaming the hole to take the next larger bolt. Usually, such factors as edge distance, clearance, or load factor must be considered. Oversized or elongated holes in noncritical members can usually be drilled or reamed to the next larger size.

Many bolt holes, particularly those in primary connecting elements, have close tolerances. Generally, it is permissible to use the first lettered drill size larger than the normal bolt diameter, except where the AN hexagon bolts are used in light drive fit (reamed) applications and where NAS close tolerance bolts or AN clevis bolts are used.

Light drive fits for bolts (specified on the repair drawings as 0.0015 inch maximum clearance between bolt and hole) are required in places where bolts are used in repair, or where they are placed in the original structure.

The fit of holes and bolts cannot be defined in terms of shaft and hole diameters; it is defined in terms of the friction between bolt and hole when sliding the bolt into place. A tight drive fit, for example, is one in which a sharp blow of a 12- or 14-ounce hammer is required to move the bolt. A bolt that requires a hard blow and sounds tight is considered to fit too tightly. A light drive fit is one in which a bolt will move when

a hammer handle is held against its head and pressed by the weight of the body.

Installation Practices

Examine the markings on the bolt head to determine that each bolt is of the correct material. It is of extreme importance to use like bolts in replacement. In every case, refer to the applicable Maintenance Instructions Manual and Illustrated Parts Breakdown.

Be sure that washers are used under both the heads of bolts and nuts unless their omission is specified. A washer guards against mechanical damage to the material being bolted and prevents corrosion of the structural members. An aluminum alloy washer should be used under the head and nut of a steel bolt securing aluminum alloy or magnesium alloy members. Any corrosion that occurs then attacks the washer rather than the members. Steel washers should be used when joining steel members with steel bolts.

Whenever possible, place the bolt with the head on top or in the forward position. This positioning tends to prevent the bolt from slipping out if the nut is accidentally lost.

Be certain that the bolt grip length is correct. Grip length is the length of the unthreaded portion of the bolt shank. Generally speaking, the grip length should equal the thickness of the material being bolted together. However, bolts of slightly greater grip length may be used if washers are placed under the nut or the bolt head. In the case of plate nuts, add shims under the plate.

Safetying of Bolts and Nuts

It is very important that all bolts or nuts, except the self-locking type, be safetyed after installation. This prevents them from loosening in flight due to vibration. Methods of safetying are discussed later in this chapter.

Repair of Damaged Internal Threads

Installation or replacement of bolts is simple when compared to the installation or replacement of studs. Bolt heads and nuts are cut in the open, whereas studs are installed into internal threads in a casting or built-up assembly. Damaged threads on bolts or nuts can be seen and only require replacement of the defective part. If internal threads are damaged, two alternatives are apparent: the part may be replaced or the threads repaired or replaced. Correction of the thread problem is usually cheaper and more convenient. Two

methods of repairing are by replacement bushings or helicoils.

Replacement Bushings

Bushings are usually special material (steel or brass spark plug bushings into aluminum cylinder heads). A material that will resist wear is used where removal and replacement is frequent. The external threads on the bushing are usually coarse. The bushing is installed, a thread lock compound may or may not be used, and staked to prevent loosening. Many bushings have left-hand threads external and right-hand threads internal. With this installation, removal of the bolt or stud (right-hand threads) tends to tighten the bushing.

Bushings for common installations, such as spark plugs, may be up to 0.040 oversize (in increments of 0.005). Original installation and overhaul shop replacements are shrunk fit: a heated cylinder head and a frozen bushing.

Helicoils

Helicoils are precision formed screw thread coils of 18-8 stainless steel wire having a diamond shaped cross section. [Figure 5-31] They form unified coarse or unified fine thread classes 2-band 3B when assembled into (helicoil) threaded holes. The assembled insert accommodates UNJ (controlled radius root) male threaded members. Each insert has a driving tang with a notch to facilitate removal of the tang after the insert is screwed into a helicoil tapped hole.

They are used as screw thread bushings. In addition to being used to restore damaged threads, they are used in the original design of missiles, aircraft engines, and all types of mechanical equipment and accessories to

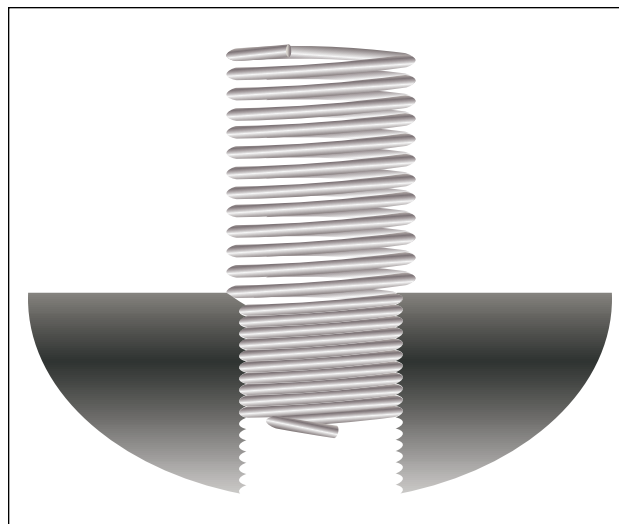

Figure 5-31. Helicoil insert.

protect and strengthen tapped threads in light materials, metals, and plastics, particularly in locations which require frequent assembly and disassembly, and/or where a screw locking action is desired.

Helicoil installation [Figure 5-32] is a 5 or 6 step operation, depending upon how the last step is classed.

Step 1: Determine what threads are damaged.

Step 2: (a) New installation of helicoil. Drill out damaged threads to minimum depth specified.

(b) Previously installed helicoil. Using proper size extracting tool, place edge of blade in 90° from the edge of the insert. Tap with hammer to seat tool. Turn to left, applying pressure, until insert backs out. Threads are not damaged if insert is properly removed.

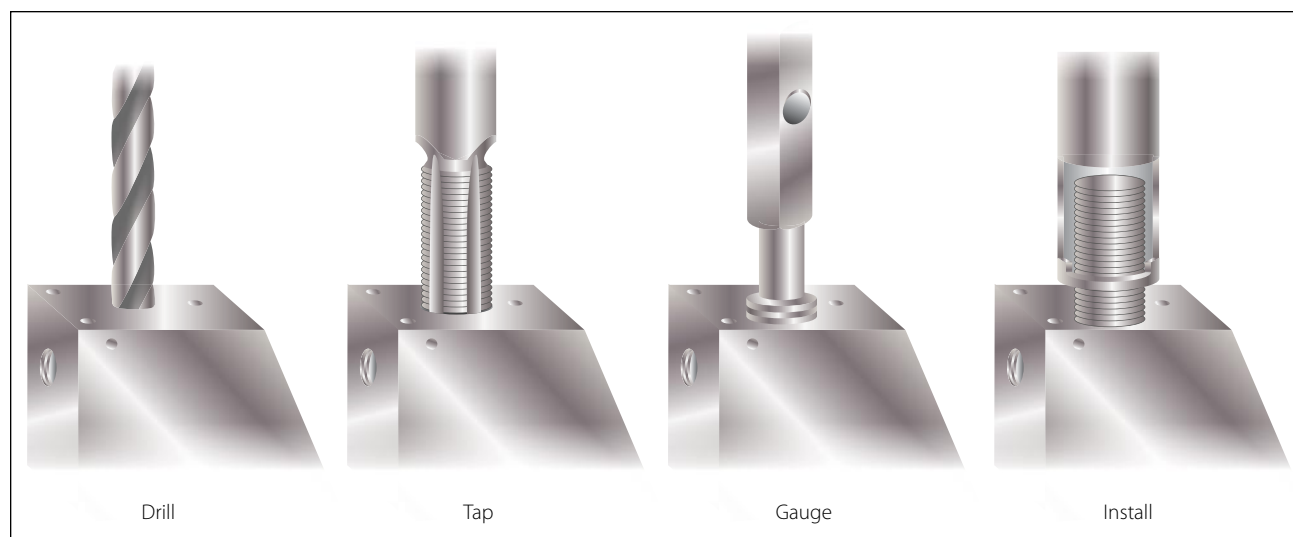

Figure 5-32. Helicoil installation.

Step 3: Tap. Use the tap of required nominal thread size. The tapping procedure is the same as standard thread tapping. Tap length must be equal to or exceed the requirement.

Step 4: Gauge. Threads may be checked with a helicoil thread gauge.

Step 5: Insert assembly. Using proper tool, install insert to a depth that puts end of top coil $\frac{1}{4}$ to $\frac{1}{2}$ turn below the top surface of the tapped hole.

Step 6: Tang breakoff. Select proper breakoff tool. Tangs should be removed from all drilled through holes. In blind holes, the tangs may be removed when necessary if enough hole depth is provided below the tang of the installed insert.

These are not to be considered specific instructions on helicoil installation. The manufacturer's instruction must be followed when making an installation.

Helicoils are available for the following threads: unified coarse, unified fine, metric, spark plug, and national taper pipe threads.

Fastener Torque

Torque and Torque Wrenches

As the speed of an aircraft increases, each structural member becomes more highly stressed. It is therefore extremely important that each member carry no more and no less than the load for which it was designed. To distribute the loads safely throughout a structure, it is necessary that proper torque be applied to all nuts, bolts, studs, and screws. Using the proper torque allows the structure to develop its designed strength and greatly reduces the possibility of failure due to fatigue.

Torque wrenches. The three most commonly used torque wrenches are the flexible beam, rigid frame, and the ratchet types. [Figure 5-33] When using the flexible beam and the rigid frame torque wrenches, the torque value is read visually on a dial or scale mounted on the handle of the wrench.

To use the ratchet type, unlock the grip and adjust the handle to the desired setting on the micrometer type scale, then relock the grip. Install the required socket or adapter to the square drive of the handle. Place the wrench assembly on the nut or bolt and pull the wrench assembly on the nut or bolt and pull in a clockwise direction with a smooth, steady motion. (A fast or jerky motion will result in an improperly torqued unit.) When the applied torque reaches the torque value indicated on

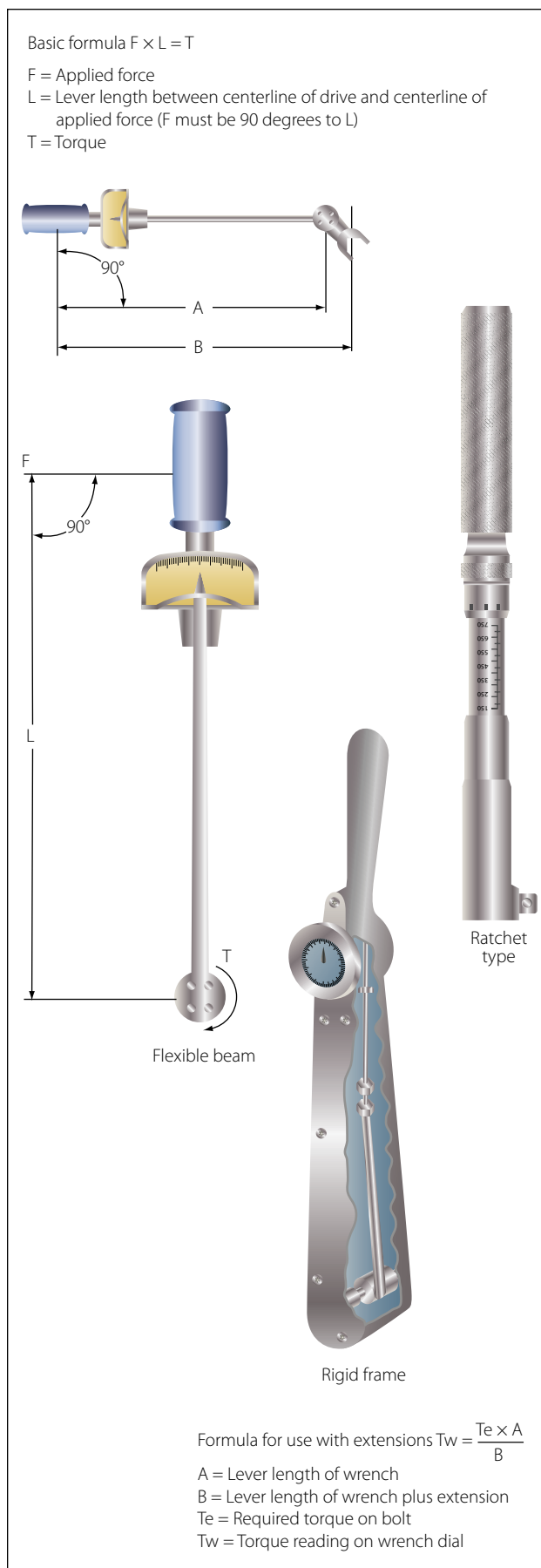

Figure 5-33. Common torque wrenches.

the handle setting, the handle will automatically release or “break” and move freely for a short distance.

The release and free travel is easily felt, so there is no doubt about when the torquing process is completed.

To assure getting the correct amount of torque on the fasteners, all torque wrenches must be tested at least once a month or more often if necessary.

Note: It is not advisable to use a handle length extension on a flexible beam type torque wrench at any time. A handle extension alone has no effect on the reading of the other types. The use of a drive end extension on any type of torque wrench makes the use of the formula mandatory. When applying the formula, force must be applied to the handle of the torque wrench at the point from which the measurements were taken. If this is not done, the torque obtained will be incorrect.

Torque Tables. Use the standard torque table as a guide in tightening nuts, studs, bolts, and screws whenever specific torque values are not called out in maintenance procedures. The following rules apply for correct use of the torque table: [Figure 5-34]

1. To obtain values in foot-pounds, divide inch-pounds by 12.
2. Do not lubricate nuts or bolts except for corrosion-resistant steel parts or where specifically instructed to do so.
3. Always tighten by rotating the nut first if possible. When space considerations make it necessary to tighten by rotating the bolt head, approach the high side of the indicated torque range. Do not exceed the maximum allowable torque value.
4. Maximum torque ranges should be used only when materials and surfaces being joined are of sufficient thickness, area, and strength to resist breaking, warping, or other damage.
5. For corrosion resisting steel nuts, use torque values given for shear type nuts.
6. The use of any type of drive end extension on a torque wrench changes the dial reading required to obtain the actual values indicated in the standard torque range tables. When using a drive end extension, the torque wrench reading must be computed by use of the proper formula, which is included in the handbook accompanying the torque wrench.

Cotter Pin Hole Line Up

When tightening castellated nuts on bolts, the cotter pin holes may not line up with the slots in the nuts for the range of recommended values. Except in cases of highly stressed engine parts, the nut may not be over torque. Remove hardware and realign the holes. The torque loads specified may be used for all unlubricated cadmium-plated steel nuts of the fine or coarse thread series which have approximately equal number of threads and equal face bearing areas. These values do not apply where special torque requirements are specified in the maintenance manual.

If the head end, rather than the nut, must be turned in the tightening operation, maximum torque values may be increased by an amount equal to shank friction, provided the latter is first measured by a torque wrench.

Aircraft Rivets

Sheets of metal must be fastened together to form the aircraft structure, and this is usually done with solid aluminum alloy rivets. A rivet is a metal pin with a formed head on one end when the rivet is manufactured. The shank of the rivet is inserted into a drilled hole, and its shank is then upset (deformed) by a hand or pneumatic tool. The second head, formed either by hand or by pneumatic equipment, is called a “shop head.” The shop head functions in the same manner as a nut on a bolt. In addition to their use for joining aircraft skin sections, rivets are also used for joining spar sections, for holding rib sections in place, for securing fittings to various parts of the aircraft, and for fastening innumerable bracing members and other parts together. The rivet creates a bond that is at least as strong as the material being joined.

Two of the major types of rivets used in aircraft are the common solid shank type, which must be driven using a bucking bar, and the special (blind) rivets, which may be installed where it is impossible to use a bucking bar.

Aircraft rivets are not hardware store rivets. Rivets purchased at a hardware store should never be used as a substitute for aircraft quality rivets. The rivets may be made from very different materials, the strength of the rivets differs greatly, and their shear strength qualities are very different. The countersunk heads on hardware store rivets are 78°, whereas countersunk aircraft rivets have 100° angle heads for more surface contact to hold it in place.

Bolt, Stud or Screw Size		Torque Values in Inch-Pounds for Tightening Nuts			
		On standard bolts, studs and screws having a tensile strength of 125,000 to 140,000 psi		On bolts, studs, and screws having a tensile strength of 140,000 to 160,000 psi	On high-strength bolts, studs, and screws having a tensile strength of 160,000 psi and over
		Shear type nuts (AN320, AN364 or equivalent)	Tension type nuts and threaded machine parts (AN-310, AN365 or equivalent)	Any nut, except shear type	Any nut, except shear type
8-32	8-36	7-9	12-15	14-17	15-18
10-24	10-32	12-15	20-25	23-30	25-35
1/4-20		25-30	40-50	45-49	50-68
	1/4-28	30-40	50-70	60-80	70-90
5/16-18		48-55	80-90	85-117	90-144
	5/16-24	60-85	100-140	120-172	140-203
3/8-16		95-110	160-185	173-217	185-248
	3/8-24	95-110	160-190	175-271	190-351
7/16-14		140-155	235-255	245-342	255-428
	7/16-20	270-300	450-500	475-628	500-756
1/2-13		240-290	400-480	440-636	480-792
	1/2-20	290-410	480-690	585-840	690-990
9/16-12		300-420	500-700	600-845	700-990
	9/16-18	480-600	800-1000	900-1,220	1,000-1,440
5/8-11		420-540	700-900	800-1,125	900-1,350
	5/8-18	660-780	1,100-1,300	1,200-1,730	1,300-2,160
3/4-10		700-950	1,150-1,600	1,380-1,925	1,600-2,250
	3/4-16	1,300-1,500	2,300-2,500	2,400-3,500	2,500-4,500
7/8-9		1,300-1,800	2,200-3,000	2,600-3,570	3,000-4,140
	7/8-14	1,500-1,800	2,500-3,000	2,750-4,650	3,000-6,300
1"-8		2,200-3,000	3,700-5,000	4,350-5,920	5,000-6,840
	1"-14	2,200-3,300	3,700-5,500	4,600-7,250	5,500-9,000
1 1/8-8		3,300-4,000	5,500-6,500	6,000-8,650	6,500-10,800
	1 1/8-12	3,000-4,200	5,000-7,000	6,000-10,250	7,000-13,500
1 1/4-8		4,000-5,000	6,500-8,000	7,250-11,000	8,000-14,000
	1 1/4-12	5,400-6,600	9,000-11,000	10,000-16,750	11,000-22,500

Figure 5-34. Standard torque table (inch-pounds).

Standards and Specifications

The FAA requires that the structural strength and integrity of type-certificated aircraft conform to all airworthiness requirements. These requirements apply to performance, structural strength, and integrity as well flight characteristics. To meet these requirements, each aircraft must meet the same standards. To accomplish standardization, all materials and hardware must be manufactured to a standard of quality. Specifications and standards for aircraft hardware are usually identified by the organization that originated them. Some of the common standardizing organizations include:

AMS	Aeronautical Material Specifications
AN	Air Force-Navy
AND	Air Force-Navy Design
AS	Aeronautical Standard
ASA	American Standards Association
ASTM	American Society for Testing Materials
MS	Military Standard
NAF	Naval Aircraft Factory
NAS	National Aerospace Standard
SAE	Society of Automotive Engineers

When a MS20426-AD4-6 rivet is required, the specifications have already been written for it in the Military Standard (MS) specifications. That information is available to the aircraft manufacturers and to the rivet manufacturers as well as to the mechanic. The specifications designate the material to be used as well as the head type, diameter, and length of the rivet. The use of standardized materials in the production of aircraft makes each aircraft exactly the same as the previous one and makes them less expensive to build.

Aircraft rivets are manufactured to much higher standards and specifications than rivets manufactured for general use. When aircraft manufacturers started building all-metal aircraft in the 1930s, different manufacturers had different rivet head designs. Brazier heads, modified brazier heads, button heads, mushroom heads, flatheads, and 78° countersunk heads were used. As aircraft standardized, four rivet head designs almost completely replaced all of the others. Rivets exposed to the airflow over the top of the structure are usually either universal head MS20470 or 100° countersunk head MS20426 rivets. For rivets used in internal structures, the roundhead MS20430 and the flathead MS20442 are generally used.

Solid Shank Rivets

Solid shank rivets are generally used in repair work. They are identified by the kind of material of which they are made, their head type, size of shank, and their temper condition. The designation of the solid shank rivet head type, such as universal head, roundhead, flathead, countersunk head, and brazier head, depends on the cross-sectional shape of the head. [Figure 5-37] The temper designation and strength are indicated by special markings on the head of the rivet.

The material used for the majority of aircraft solid shank rivets is aluminum alloy. The strength and temper conditions of aluminum alloy rivets are identified by digits and letters similar to those adopted for the identification of strength and temper conditions of aluminum and aluminum alloy stock. The 1100, 2017-T, 2024-T, 2117-T, and 5056 rivets are the five grades usually available.

The 1100 rivet, which is composed of 99.45 percent pure aluminum, is very soft. It is for riveting the softer aluminum alloys, such as 1100, 3003, and 5052, which are used for nonstructural parts (all parts where strength is not a factor). The riveting of map cases is a good example of where a rivet of 1100 aluminum alloy may be used.

The 2117-T rivet, known as the field rivet, is used more than any other for riveting aluminum alloy structures. The field rivet is in wide demand because it is ready for use as received and needs no further heat treating or annealing. It also has a high resistance to corrosion.

The 2017-T and 2024-T rivets are used in aluminum alloy structures where more strength is needed than is obtainable with the same size 2217-T rivet. These rivets are known as “ice box rivets,” are annealed, and must be kept refrigerated until they are to be driven. The 2017-T rivet should be driven within approximately 1 hour and the 2024-T rivet within 10 to 20 minutes after removal from refrigeration.

The 5056 rivet is used for riveting magnesium alloy structures because of its corrosion-resistant qualities in combination with magnesium.

Mild steel rivets are used for riveting steel parts. The corrosion-resistant steel rivets are for riveting corrosion-resistant steels in firewalls, exhaust stack brackets, and similar structures.

Monel rivets are used for riveting nickel-steel alloys. They can be substituted for those made of corrosion-resistant steel in some cases.

The use of copper rivets in aircraft repair is limited. Copper rivets can be used only on copper alloys or nonmetallic materials such as leather.

Metal temper is an important factor in the riveting process, especially with aluminum alloy rivets. Aluminum alloy rivets have the same heat-treating characteristics as aluminum alloy stock. They can be hardened and annealed in the same manner as aluminum. The rivet must be soft, or comparatively soft, before a good head can be formed. The 2017-T and 2024-T rivets are annealed before being driven. They harden with age.

The process of heat treating (annealing) rivets is much the same as that for stock. Either an electric air furnace, a salt bath, or a hot oil bath is needed. The heat-treating range, depending on the alloy, is 625 °F to 950 °F. For convenient handling, rivets are heated in a tray or a wire basket. They are quenched in cold water (70 °F) immediately after heat treating.

The 2017-T and 2024-T rivets, which are heat-treatable rivets, begin to age harden within a few minutes after being exposed to room temperature. Therefore, they must be used immediately after quenching or else be placed in cold storage.

The most commonly used means for holding heat-treatable rivets at low temperature (below 32 °F) is to keep them in a refrigerator. They are referred to as “icebox” rivets. Under this storage condition, they will remain soft enough for driving for periods up to 2 weeks. Any rivets not used within that time should be removed for reheat treating.

Icebox rivets attain about one-half their maximum strength in approximately 1 hour after driving and full strength in about 4 days. When 2017-T rivets are exposed to room temperature for 1 hour or longer, they must be subject to reheat treatment. This also applies to 2024-T rivets exposed to room temperature for a period exceeding 10 minutes.

Once an icebox rivet has been taken from the refrigerator, it should not be mixed with the rivets still in cold storage. If more rivets are removed from the refrigerator than can be used in 15 minutes, they should be placed in a separate container and stored for reheat treatment. Heat treatment of rivets may be repeated a number of times if done properly. Proper heating times and temperatures are shown in Figure 5-35.

Most metals, and therefore aircraft rivet stock, are subject to corrosion. Corrosion may be the result of local climatic conditions or the fabrication process used. It

Heating Time — Air Furnace		
Rivet Alloy	Time at Temperature	Heat Treating Temperature
2024	1 hour	910 °F–930 °F
2017	1 hour	925 °F–950 °F
Heating Time — Salt Bath		
Rivet Alloy	Time at Temperature	Heat Treating Temperature
2024	30 minutes	910 °F–930 °F
2017	30 minutes	925 °F–950 °F

Figure 5-35. Rivet heating times and temperatures.

is reduced to a minimum by using metals which are highly resistant to corrosion and possess the correct strength-to-weight ratio.

Ferrous metals placed in contact with moist salt air will rust if not properly protected. Nonferrous metals, those without an iron base, do not rust, but a similar process known as corrosion takes place. The salt in moist air (found in the coastal areas) attacks the aluminum alloys. It is a common experience to inspect the rivets of an aircraft which has been operated near salt water and find them badly corroded.

If a copper rivet is inserted into an aluminum alloy structure, two dissimilar metals are brought in contact with each other. Remember, all metals possess a small electrical potential. Dissimilar metals in contact with each other in the presence of moisture cause an electrical current to flow between them and chemical byproducts to be formed. Principally, this results in the deterioration of one of the metals.

Certain aluminum alloys react to each other and, therefore, must be thought of as dissimilar metals. The commonly used aluminum alloys may be divided into the two groups shown in Figure 5-36.

Group A	Group B
1100	2117
3003	2017
5052	2124
6053	7075

Figure 5-36. Aluminum groupings.

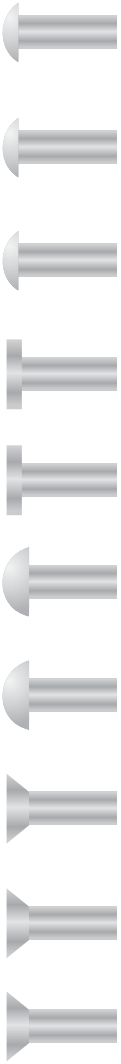

Material	Head Marking	AN Material Code	AN425 78° Counter-sunk Head	AN426 100° Counter-sunk Head MS20426*	AN427 100° Counter-sunk Head MS20427*	AN430 Round Head MS20470*	AN435 Round Head MS20613* MS20615*	AN441 Flat Head	AN442 Flat Head MS20470*	AN455 Brazier Head MS20470*	AN456 Brazier Head MS20470*	AN470 Universal Head MS20470*	Heat Treat Before Use	Shear Strength psi	Bearing Strength psi
1100	Plain	A	X	X		X			X	X	X	X	No	10,000	25,000
2117T	Recessed Dot	AD	X	X		X			X	X	X	X	No	30,000	100,000
2017T	Raised Dot	D	X	X		X			X	X	X	X	Yes	34,000	113,000
2017T-HD	Raised Dot	D	X	X		X			X	X	X	X	No	38,000	126,000
2024T	Raised Double Dash	DD	X	X		X			X	X	X	X	Yes	41,000	136,000
5056T	Raised Cross	B		X		X			X	X	X	X	No	27,000	90,000
7075-T73	Three Raised Dashes		X	X		X			X	X	X	X	No		
Carbon Steel	Recessed Triangle				X		X MS20613*	X					No	35,000	90,000
Corrosion Resistant Steel	Recessed Dash	F			X		X MS20613*						No	65,000	90,000
Copper	Plain	C			X		X	X					No	23,000	
Monel	Plain	M			X			X					No	49,000	
Monel (Nickel-Copper Alloy)	Recessed Double Dots	C					X MS20615*						No	49,000	
Brass	Plain						X MS20615*						No		
Titanium	Recessed Large and Small Dot			MS20426									No	95,000	

* New specifications are for design purposes.

Figure 5-37. Rivet identification chart.

Members within either group A or group B can be considered as similar to each other and will not react to others within the same group. A corroding action will take place, however, if any metal of group A comes in contact with a metal in group B in the presence of moisture.

Avoid the use of dissimilar metals whenever possible. Their incompatibility is a factor which was considered when the AN Standards were adopted. To comply with AN Standards, the manufacturers must put a protective surface coating on the rivets. This may be zinc chromate, metal spray, or an anodized finish.

The protective coating on a rivet is identified by its color. A rivet coated with zinc chromate is yellow, an anodized surface is pearl gray, and the metal sprayed rivet is identified by a silvery gray color. If a situation arises in which a protective coating must be applied on the job, paint the rivet with zinc chromate before it is used and again after it is driven.

Identification

Markings on the heads of rivets are used to classify their characteristics. These markings may be either a raised teat, two raised teats, a dimple, a pair of raised dashes, a raised cross, a single triangle, or a raised dash; some other heads have no markings.

The different markings indicate the composition of the rivet stock. As explained previously, the rivets have different colors to identify the manufacturers' protective surface coating.

Roundhead rivets are used in the interior of the aircraft, except where clearance is required for adjacent members. The roundhead rivet has a deep, rounded top surface. The head is large enough to strengthen the sheet around the hole and, at the same time, offer resistance to tension.

The flathead rivet, like the roundhead rivet, is used on interior structures. It is used where maximum strength is needed and where there isn't sufficient clearance to use a roundhead rivet. It is seldom, if ever, used on external surfaces. The brazier head rivet has a head of large diameter, which makes it particularly adaptable for riveting thin sheet stock (skin). The brazier head rivet offers only slight resistance to the airflow, and because of this factor, it is frequently used for riveting skin on exterior surfaces, especially on aft sections of the fuselage and empennage. It is used for riveting thin sheets exposed to the slipstream. A modified brazier

head rivet is also manufactured; it is simply a brazier head of reduced diameter.

The universal head rivet is a combination of the roundhead, flathead, and brazier head. It is used in aircraft construction and repair in both interior and exterior locations. When replacement is necessary for protruding head rivets—roundhead, flathead, or brazier head—they can be replaced by universal head rivets.

The countersunk head rivet is flat topped and beveled toward the shank so that it fits into a countersunk or dimpled hole and is flush with the material's surface. The angle at which the head slopes may vary from 78° to 120°. The 100° rivet is the most commonly used type. These rivets are used to fasten sheets over which other sheets must fit. They are also used on exterior surfaces of the aircraft because they offer only slight resistance to the slipstream and help to minimize turbulent airflow.

The markings on the heads of rivets indicate the material of which they are made and, therefore, their strength. Figure 5-37 identifies the rivet head markings and the materials indicated by them. Although there are three materials indicated by a plain head, it is possible to distinguish their difference by color. The 1100 is aluminum color; the mild steel is a typical steel color; and the copper rivet is a copper color. Any head marking can appear on any head style of the same material.

Each type of rivet is identified by a part number so that the user can select the correct rivet for the job. The type of rivet head is identified by AN or MS standard numbers. The numbers selected are in series and each series represents a particular type of head. [Figure 5-37]

The most common numbers and the types of heads they represent are:

- AN426 or MS20426—countersunk head rivets (100°)
- AN430 or MS20430—roundhead rivets
- AN441—flathead rivets
- AN456—brazier head rivets
- AN470 or MS20470—universal head rivets

There are also letters and numbers added to a part number. The letters designate alloy content; the num-

bers designate rivet diameter and length. The letters in common use for alloy designation are:

- A—aluminum alloy, 1100 or 3003 composition
- AD—aluminum alloy, 2117-T composition
- D—aluminum alloy, 2017-T composition
- DD—aluminum alloy, 2024-T composition
- B—aluminum alloy, 5056 composition
- C—copper
- M—monel

The absence of a letter following the AN standard number indicates a rivet manufactured from mild steel.

The first number following the material composition letters expresses the diameter of the rivet shank in 32nds of an inch (Examples: 3 indicates $\frac{3}{32}$, 5 indicates $\frac{5}{32}$, and so forth). [Figure 5-38]

The last number(s), separated by a dash from the preceding number, expresses the length of the rivet shank in 16ths of an inch (Examples: 3 indicates $\frac{3}{16}$, 7 indicates $\frac{7}{16}$, 11 indicates $\frac{11}{16}$, and so forth). [Figure 5-38]

An example of identification marking of a rivet is:

- AN470AD3-5—complete part number
- AN—Air Force-Navy standard number
- 470—universal head rivet
- AD—2117-T aluminum alloy
- 3— $\frac{3}{32}$ in diameter
- 5— $\frac{5}{16}$ in length

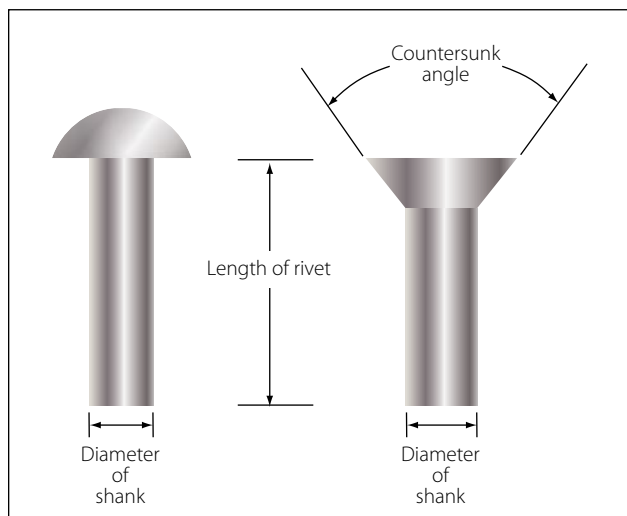

Figure 5-38. Methods of measuring rivets.

Blind Rivets

There are many places on an aircraft where access to both sides of a riveted structure or structural part is impossible, or where limited space will not permit the use of a bucking bar. Also, in the attachment of many nonstructural parts, such as aircraft interior furnishings, flooring, deicing boots, and the like, the full strength of solid shank rivets is not necessary.

For use in such places, special rivets have been designed which can be bucked from the front. They are sometimes lighter than solid shank rivets, yet amply strong for their intended use. These rivets are produced by several manufacturers and have unique characteristics that require special installation tools, special installation procedures and special removal procedures. That is why they are called special rivets. Because these rivets are often inserted in locations where one head (usually the shop head) cannot be seen, they are also called blind rivets.

Mechanically Expanded Rivets

Two classes of mechanically expanded rivets are discussed here:

- (1) Nonstructural.
 - (a) Self-plugging (friction lock) rivets.
 - (b) Pull-thru rivets.
- (2) Mechanical lock, flush fracturing, self plugging rivets.

Self-Plugging Rivets (friction lock)

The self-plugging (friction lock) blind rivets are manufactured by several companies; the same general basic information about their fabrication, composition, uses, selection, installation, inspection, and removal procedures apply to all of them.

Self-plugging (friction lock) rivets are fabricated in two parts: a rivet head with a hollow shank or sleeve, and a stem that extends through the hollow shank. Figure 5-39 illustrates a protruding head and a countersunk head self-plugging rivet produced by one manufacturer.

Several events, in their proper sequence, occur when a pulling force is applied to the stem of the rivet: (1) the stem is pulled into the rivet shank; (2) the mandrel portion of the stem forces the rivet shank to expand; and (3) when friction (or pulling action pressure) becomes great enough, it will cause the stem to snap at a breakoff groove on the stem. The plug portion (bottom end of the stem) is retained in the shank of the rivet giving

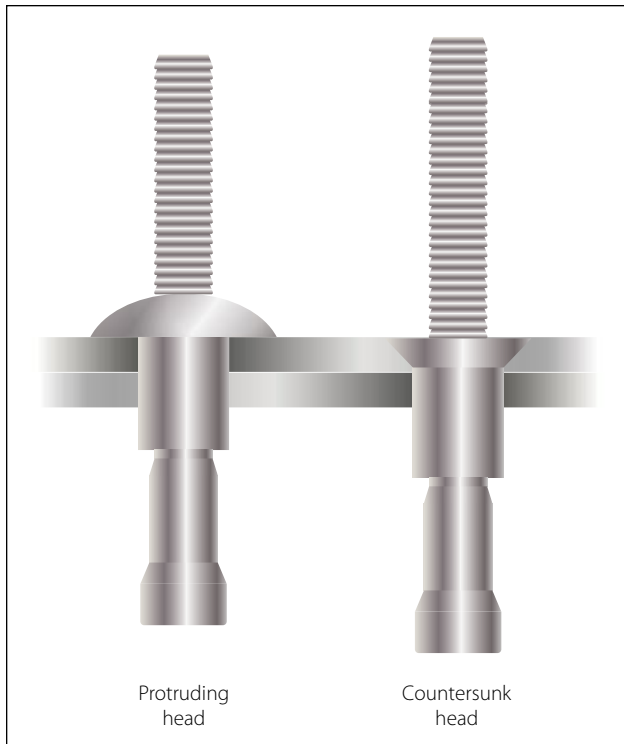

Figure 5-39. Self-plugging (friction lock) rivets.

the rivet much greater shear strength than could be obtained from a hollow rivet.

Self-plugging (friction lock) rivets are fabricated in two common head styles: (1) a protruding head similar to the MS20470 or universal head, and (2) a 100° countersunk head. Other head styles are available from some manufacturers.

The stem of the self-plugging (friction lock) rivet may have a knot or knob on the upper portion, or it may have a serrated portion. [Figure 5-39]

Self-plugging (friction lock) rivets are fabricated from several materials. Rivets are available in the following material combinations: stem 2017 aluminum alloy and sleeve 2117 aluminum alloy; stem 2017 aluminum alloy and sleeve 5056 aluminum alloy; and stem steel and sleeve steel.

Self-plugging (friction lock) rivets are designed so that installation requires only one person; it is not necessary to have the work accessible from both sides. The pulling strength of the rivet stem is such that a uniform job can always be assured. Because it is not necessary to have access to the opposite side of the work, self-plugging (friction lock) rivets can be used to attach assemblies to hollow tubes, corrugated sheet, hollow boxes, and so forth. Because a hammering force is not

necessary to install the rivet, it can be used to attach assemblies to plywood or plastics.

Factors to consider in the selection of the correct rivet for installation are: (1) installation location, (2) composition of the material being riveted, (3) thickness of the material being riveted, and (4) strength desired.

If the rivet is to be installed on an aerodynamically smooth surface, or if clearance for an assembly is needed, countersunk head rivets should be selected. In other areas where clearance or smoothness is not a factor, the protruding head type rivet may be utilized.

Material composition of the rivet shank depends upon the type of material being riveted. Aluminum alloy 2117 shank rivets can be used on most aluminum alloys. Aluminum alloy 5056 shank rivets should be used when the material being riveted is magnesium. Steel rivets should always be selected for riveting assemblies fabricated from steel.

The thickness of the material being riveted determines the overall length of the shank of the rivet. As a general rule, the shank of the rivet should extend beyond the material thickness approximately $\frac{3}{64}$ inch to $\frac{1}{8}$ inch before the stem is pulled. [Figure 5-40]

Pull-Thru Rivets

The pull-thru blind rivets are manufactured by several companies; the same general basic information about their fabrication, composition, uses, selection, installation, inspection, and removal procedures apply to all of them.

Pull-thru rivets are fabricated in two parts: a rivet head with a hollow shank or sleeve and a stem that extends

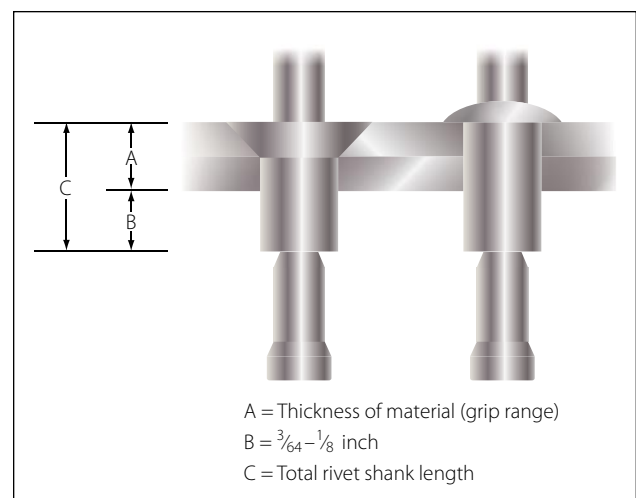

Figure 5-40. Determining length of friction lock rivets.

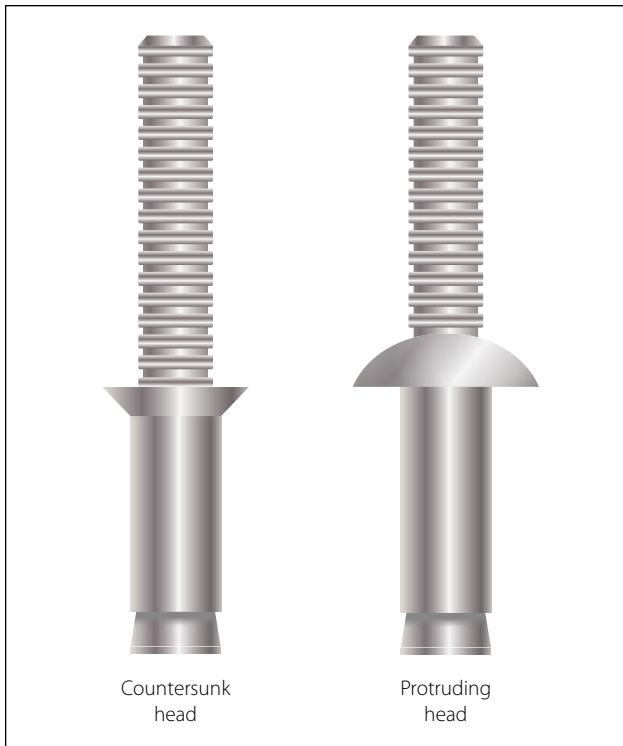

Figure 5-41. Pull-thru rivets.

through the hollow shank. Figure 5-41 illustrates a protruding head and a countersunk head pull-thru rivet.

Several events, in their proper sequence, occur when a pulling force is applied to the stem of the rivet: (1) The stem is pulled through the rivet shank; (2) the mandrel portion of the stem forces the shank to expand forming the blind head and filling the hole.

Pull-thru rivets are fabricated in two common head styles: (1) protruding head similar to the MS20470 or universal head, and (2) a 100° countersunk head. Other head styles are available from some manufacturers.

Pull-thru rivets are fabricated from several materials. Following are the most commonly used: 2117-T4 aluminum alloy, 5056 aluminum alloy, Monel.

Pull-thru rivets are designed so that installation requires only one person; it is not necessary to have the work accessible from both sides.

Factors to consider in the selection of the correct rivet for installation are: (1) installation location, (2) composition of the material being riveted, (3) thickness of the material being riveted, and (4) strength desired.

The thickness of the material being riveted determines the overall length of the shank of the rivet. As a general rule, the shank of the rivet should extend beyond the

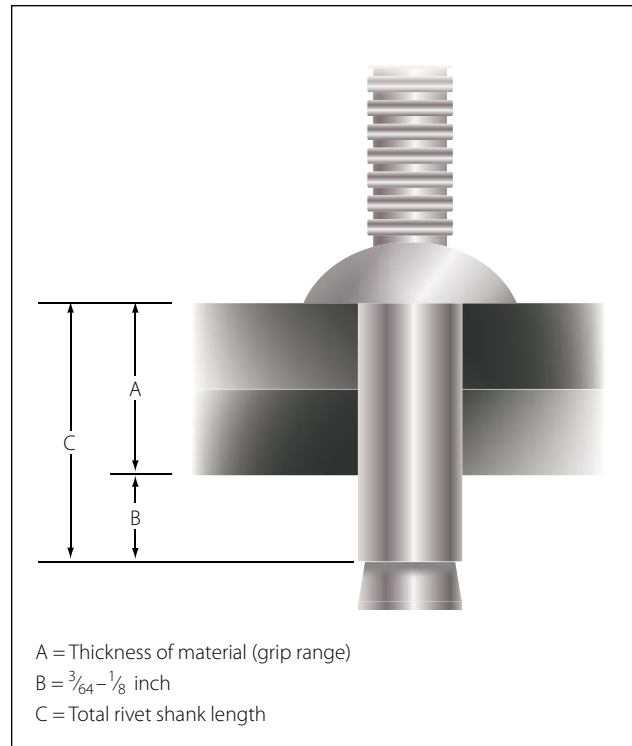

Figure 5-42. Determining length of pull-thru rivets.

material thickness approximately $\frac{3}{64}$ inch to $\frac{1}{8}$ inch before the stem is pulled. [Figure 5-42]

Each company that manufactures pull-thru rivets has a code number to help users obtain correct rivet for the grip range of a particular installation. In addition, MS numbers are used for identification purposes. Numbers are similar to those shown on the preceding pages.

Self-Plugging Rivets (Mechanical Lock)

Self-plugging (mechanical lock) rivets are similar to self-plugging (friction lock) rivets, except for the manner in which the stem is retained in the rivet sleeve. This type of rivet has a positive mechanical locking collar to resist vibrations that cause the friction lock rivets to loosen and possibly fall out. [Figure 5-45] Also, the mechanical locking type rivet stem breaks off flush with the head and usually does not require further stem trimming when properly installed. Self-plugging (mechanical lock) rivets display all the strength characteristics of solid shank rivets and in most cases can be substituted rivet for rivet.

Bulbed Cherrylock Rivets

The large blind head of this fastener introduced the word “bulb” to blind rivet terminology. In conjunction with the unique residual preload developed by the high stem break load, its proven fatigue strength makes it

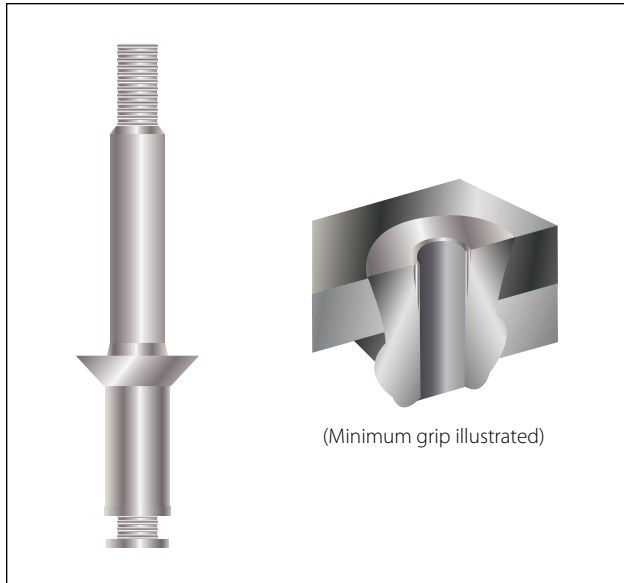

Figure 5-43. Bulbed cherrylock rivet.

the only blind rivet interchangeable structurally with solid rivets. [Figure 5-43]

Wiredraw Cherrylock Rivets

There is a wide range of sizes, materials, and strength levels from which to select. This fastener is especially suited for sealing applications and joints requiring an excessive amount of sheet takeup. [Figure 5-44]

Huck Mechanical Locked Rivets

Self-plugging (mechanical lock) rivets are fabricated in two sections: a head and shank (including a conical recess and locking collar in the head), and a serrated stem that extends through the shank. Unlike the friction lock rivet, the mechanical lock rivet has a locking collar that forms a positive lock for retention of the stem in the shank of the rivet. This collar is seated in position during the installation of the rivet.

Material

Self-plugging (mechanical lock) rivets are fabricated with sleeves (rivet shanks) of 2017 and 5056 aluminum alloys, Monel, or stainless steel.

The mechanical lock type of self-plugging rivet can be used in the same applications as the friction lock type of rivet. In addition, because of its greater stem retention characteristic, installation in areas subject to considerable vibration is recommended.

The same general requirements must be met in the selection of the mechanical lock rivet as for the friction lock rivet. Composition of the material being joined together determines the composition of the



Figure 5-44. Wiredraw cherrylock rivet.

rivet sleeve; for example, 2017 aluminum alloy rivets for most aluminum alloys and 5056 aluminum rivets for magnesium.

Figure 5-46 depicts the sequences of a typical mechanically locked blind rivet. The form and function may vary slightly between blind rivet styles and specifics should be obtained from manufacturers.

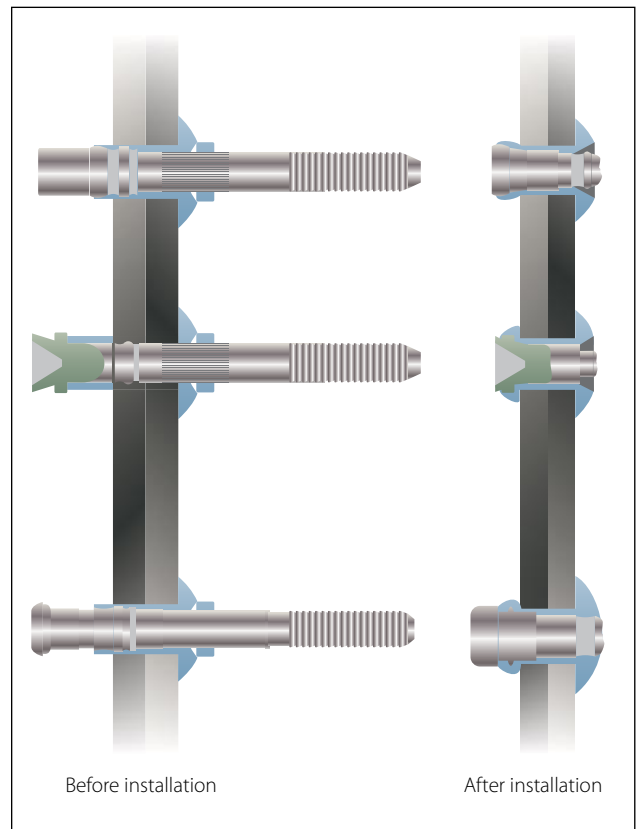

Figure 5-45. Self-plugging (mechanical lock) rivets.

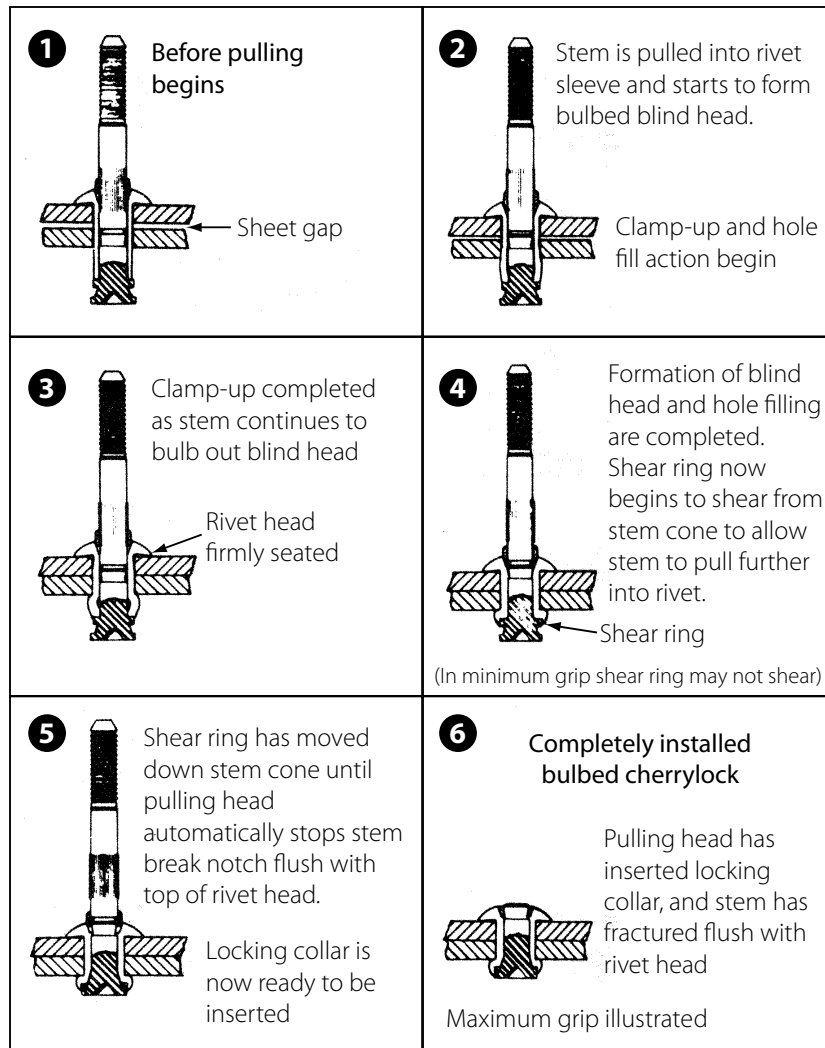

Figure 5-46. Cherrylock rivet installation.

Head Styles

Self-plugging mechanical locked blind rivets are available in several head styles depending on the installation requirements. [Figure 5-47]

Diameters

Shank diameters are measured in 1/32-inch increments and are generally identified by the first dash number: -3 indicates $\frac{3}{32}$ inch diameter, -4 indicates $\frac{1}{8}$ inch diameter, and so forth.

Both nominal and $\frac{1}{64}$ -inch oversize diameters are available.

Grip Length

Grip length refers to the maximum total sheet thickness to be riveted and is measured in $\frac{1}{6}$ of an inch. This is generally identified by the second dash number. Unless otherwise noted, most blind rivets have their grip lengths

(maximum grip) marked on the rivet head and have a total grip range of $\frac{1}{16}$ inch. [Figure 5-48]

To determine the proper grip rivet to use, measure the material thickness with a grip selection gauge (available from blind rivet manufacturers). The proper use of a grip selector gauge is shown in Figure 5-49.

The thickness of the material being riveted determines the overall length of the shank of the rivet. As a general rule, the shank of the rivet should extend beyond the material thickness approximately $\frac{3}{64}$ inch to $\frac{1}{8}$ inch before the stem is pulled. [Figure 5-50]

Rivet Identification

Each company that manufactures self-plugging (friction lock) rivets has a code number to help users obtain the correct rivet for the grip range or material thickness of a particular installation. In addition, MS numbers are used for identification purposes. Figures

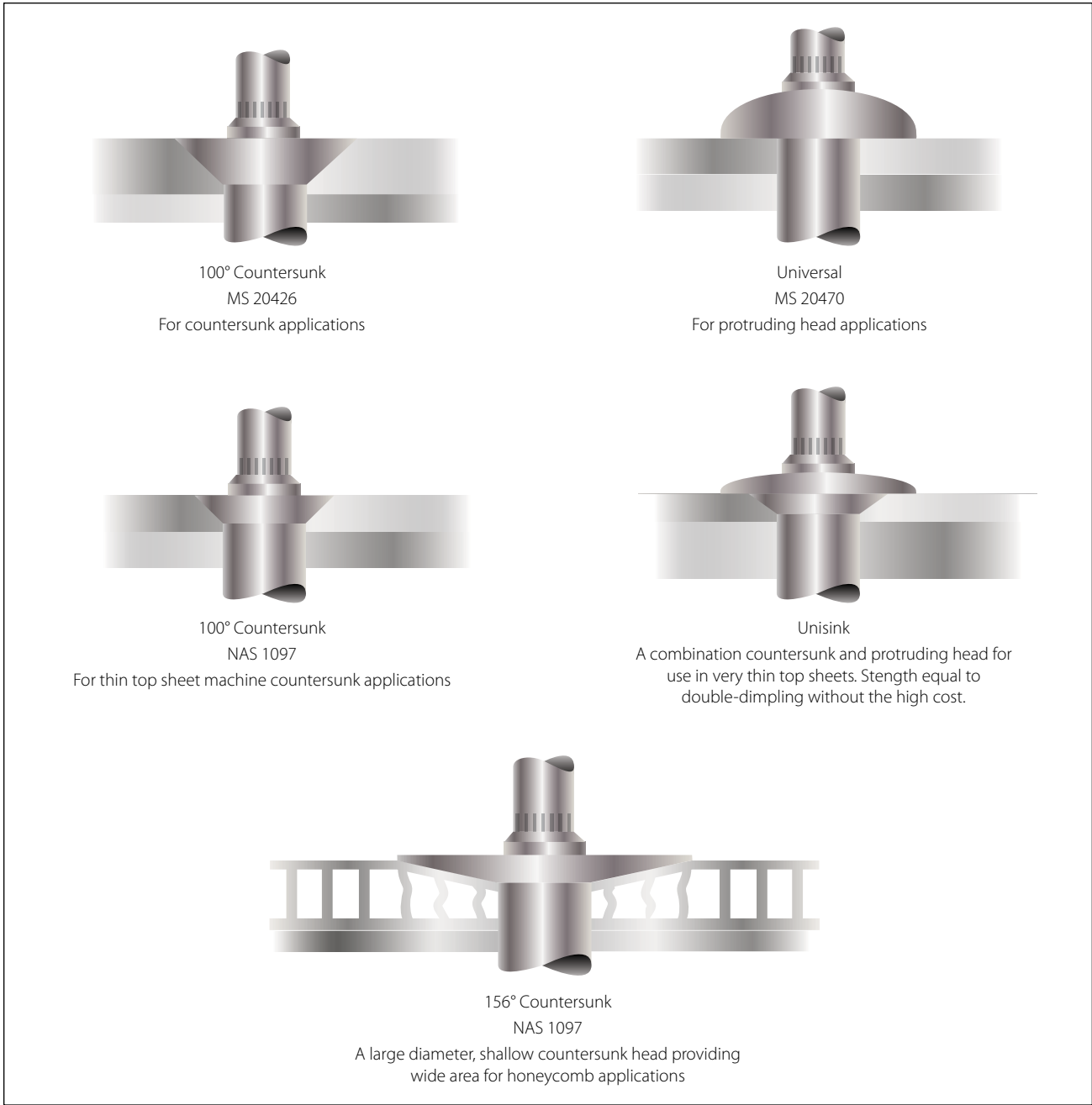

Figure 5-47. Cherrylock rivet heads.

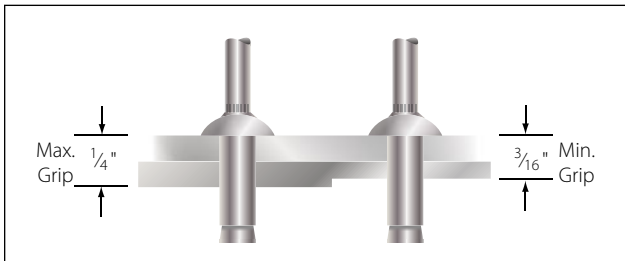

Figure 5-48. Typical grip length.

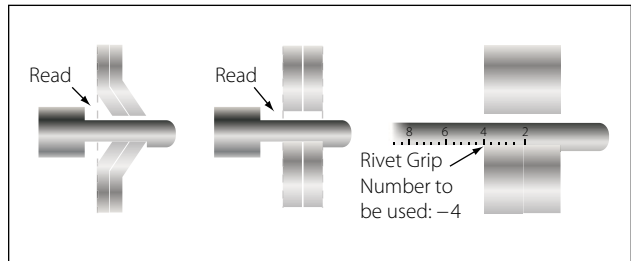

Figure 5-49. Grip gauge use.

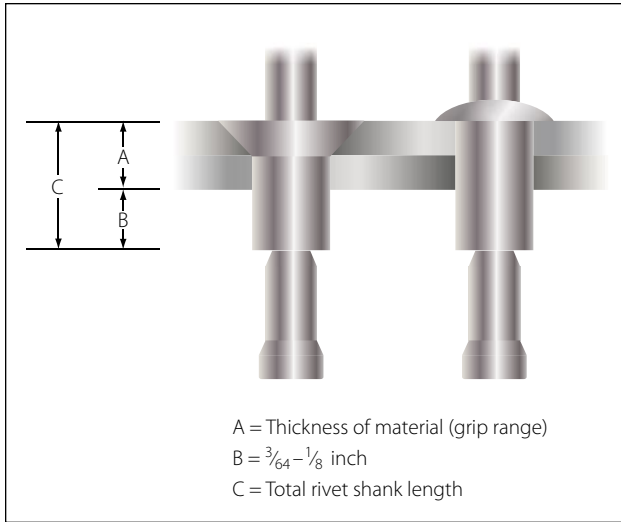

Figure 5-50. Determining rivet length.

5-51 through 5-54 contain examples of part numbers for self-plugging (friction lock) rivets that are representative of each.

Special Shear and Bearing Load Fasteners

Many special fasteners produce high strength with light weight and can be used in place of conventional AN bolts and nuts. When AN bolts are tightened with the nut, the bolt stretches, narrowing the diameter and then the bolt is no longer tight in the hole. Special fasteners eliminate this loose fit because they are held in place by a collar that is squeezed into position. These fasteners are not under the same tensile loads as a bolt during installation. Special fasteners are also used extensively for light sport aircraft (LSA). Always follow the aircraft manufacturer's recommendations.

Huck Manufacturing Comany
9SP-B A 6 3

9SP-B | Head Style
 9SP-B = brazier or universal head
 9SP-100 = 100° countersunk head

A | Material composition of shank
 A = 2017 aluminium alloy
 B = 5056 aluminium alloy
 R = mild steel

6 | Shank diameter in 32nds of an inch:
 4 = $\frac{1}{8}$ inch 6 = $\frac{3}{16}$ inch
 5 = $\frac{5}{32}$ inch 8 = $\frac{1}{4}$ inch

3 | Grip range (material thickness) in 16ths of an inch

Figure 5-51. Huck Manufacturing Comany codes.

Olympic Screw and Rivet Corporation
RV 2 0 0 4 2

RV | Manufacturer
 Olympic Screw and Rivet Corporation

2 | Rivet type
 2 = self plugging (friction lock)
 5 = hollow pull thru

0 | Material composition of shank
 0 = 2017 aluminium alloy
 5 = 5056 aluminium alloy
 7 = mild steel

0 | Head style
 0 = universal head
 1 = 100° countersunk

4 | Shank diameter in 32nds of an inch:
 4 = $\frac{1}{8}$ inch 6 = $\frac{3}{16}$ inch
 5 = $\frac{5}{32}$ inch 8 = $\frac{1}{4}$ inch

2 | Grip range in 16ths of an inch

Figure 5-52. Olympic Screw and Rivet Corporation codes.

Townsend Company, Cherry Rivet Division
CR 163 6 6

CR | Cherry rivet

163 | Series number
 Designates rivet material, type of rivet, and head style (163 = 2117 aluminium alloy, self-plugging (friction lock) rivet, protruding head)

6 | Shank diameter in 32nds of an inch:
 4 = $\frac{1}{8}$ inch 6 = $\frac{3}{16}$ inch
 5 = $\frac{5}{32}$ inch 8 = $\frac{1}{4}$ inch

6 | Grip range (material thickness):
 knob stem in 32nds of an inch; serrated stem in 16ths of an inch

Figure 5-53. Townsend Company, Cherry Rivet Division codes.

Military Standard Number
MS 20600 B 4 K 2

MS | Military Standard

20600 | Type of rivet and head style:
 20600 = self-plugging (friction lock) protruding head
 20600 = self-plugging (friction lock) 100° countersunk head

B | Material composition of sleeve:
 AD = 2117 aluminium alloy
 B = 5056 aluminium alloy

4 | Shank diameter in 32nds of an inch:
 4 = $\frac{1}{8}$ inch 6 = $\frac{3}{16}$ inch
 5 = $\frac{5}{32}$ inch 8 = $\frac{1}{4}$ inch

K | Type of stem:
 K = knot head stem
 W = serrated stem

2 | Grip range (material thickness) in 16ths of an inch

Figure 5-54. Military Standard Numbers.

Pin Rivets

Pin (Hi-Shear) rivets are classified as special rivets but are not of the blind type. Access to both sides of the material is required to install this type of rivet. Pin rivets have the same shear strength as bolts of equal diameters, are about 40 percent of the weight of a bolt, and require only about one-fifth as much time for installation as a bolt, nut, and washer combination. They are approximately three times as strong as solid shank rivets.

Pin rivets are essentially threadless bolts. The pin is headed at one end and is grooved about the circumference at the other. A metal collar is swaged onto the grooved end effecting a firm, tight fit. [Figure 5-55] Pin rivets are fabricated in a variety of materials but should be used only in shear applications. They should never be used where the grip length is less than the shank diameter.

Part numbers for pin rivets can be interpreted to give the diameter and grip length of the individual rivets. A typical part number breakdown would be:

NAS177-14-17

NAS = National Aircraft Standard

177 = 100° countersunk head rivet

OR 178 = flathead rivet

14 = Nominal diameter in 32nds of an inch

17 = Maximum grip length in 16ths of an inch

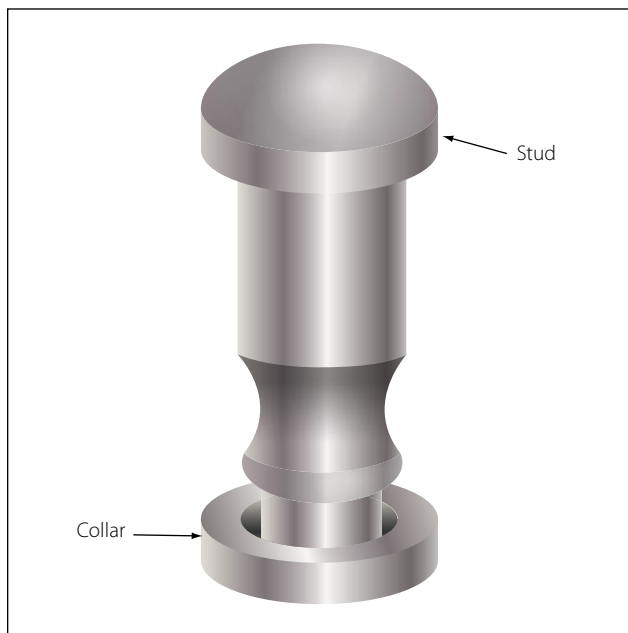

Figure 5-55. Pin (Hi-Shear) rivet.

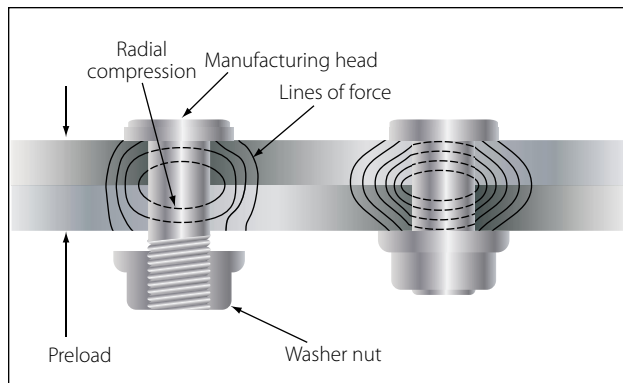

Figure 5-56. Taper-Lok special fasteners.

Taper-Lok

Taper-Loks are the strongest special fasteners used in aircraft construction. The Taper-Lok exerts a force on the walls of the hole because of its tapered shape. The Taper-Lok is designed to completely fill the hole, but unlike the rivet, it fills the hole without deforming the shank. Instead, the washer head nut squeezes the metal with tremendous force against the tapered walls of the hole. This creates radial compression around the shank and vertical compression lines as the metals are squeezed together. The combination of these forces generates strength unequalled by any other fastener. [Figure 5-56]

Hi-Tigue

The Hi-Tigue special fastener has a bead that encircles the bottom of its shank. The bead preloads the hole it fills, resulting in increased joint strength. At installation, the bead presses against the sidewall of the hole, exerting radial force that strengthens the surrounding area. Because it is preloaded, the joint is not subjected to the constant cyclic action that normally causes a joint to become cold worked and eventually fail.

Hi-Tigue fasteners are made of aluminum, titanium, and stainless steel alloys. The collars are composed of compatible metal alloys and come in two types: sealing and non-sealing. Just like the Hi-Loks, they can be installed using an Allen wrench and a box-end wrench. [Figure 5-57]

Captive Fasteners

Captive fasteners are used for quick removal of engine nacelles, inspection panels, and areas where fast and easy access is important. A captive fastener has the ability to turn in the body in which it is mounted, but which will not drop out when it is unscrewed from the part it is holding.

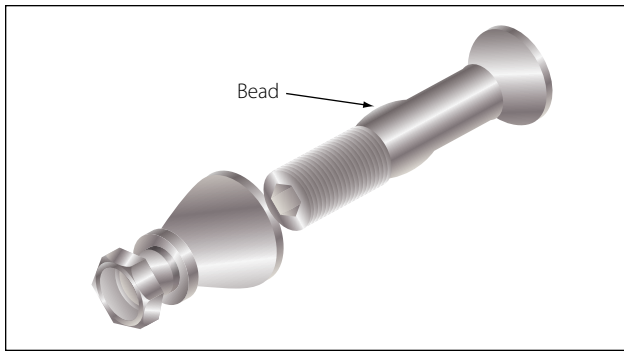

Figure 5-57. Hi-Tigue special fasteners.

Turnlock Fasteners

Turnlock fasteners are used to secure inspection plates, doors, and other removable panels on aircraft. Turnlock fasteners are also referred to by such terms as quick opening, quick action, and stressed panel fasteners. The most desirable feature of these fasteners is that they permit quick and easy removal of access panels for inspection and servicing purposes.

Turnlock fasteners are manufactured and supplied by a number of manufacturers under various trade names.

Some of the most commonly used are the Dzus, Camloc, and Airloc.

Dzus Fasteners

The Dzus turnlock fastener consists of a stud, grommet, and receptacle. Figure 5-58 illustrates an installed Dzus fastener and the various parts.

The grommet is made of aluminum or aluminum alloy material. It acts as a holding device for the stud. Grommets can be fabricated from 1100 aluminum tubing, if none are available from normal sources.

The spring is made of steel, cadmium plated to prevent corrosion. The spring supplies the force that locks or secures the stud in place when two assemblies are joined.

The studs are fabricated from steel and are cadmium plated. They are available in three head styles: wing, flush, and oval. Body diameter, length, and head type may be identified or determined by the markings found on the head of the stud. [Figure 5-59] The diameter is always measured in sixteenths of an inch. Stud length is measured in hundredths of an inch and is the dis-

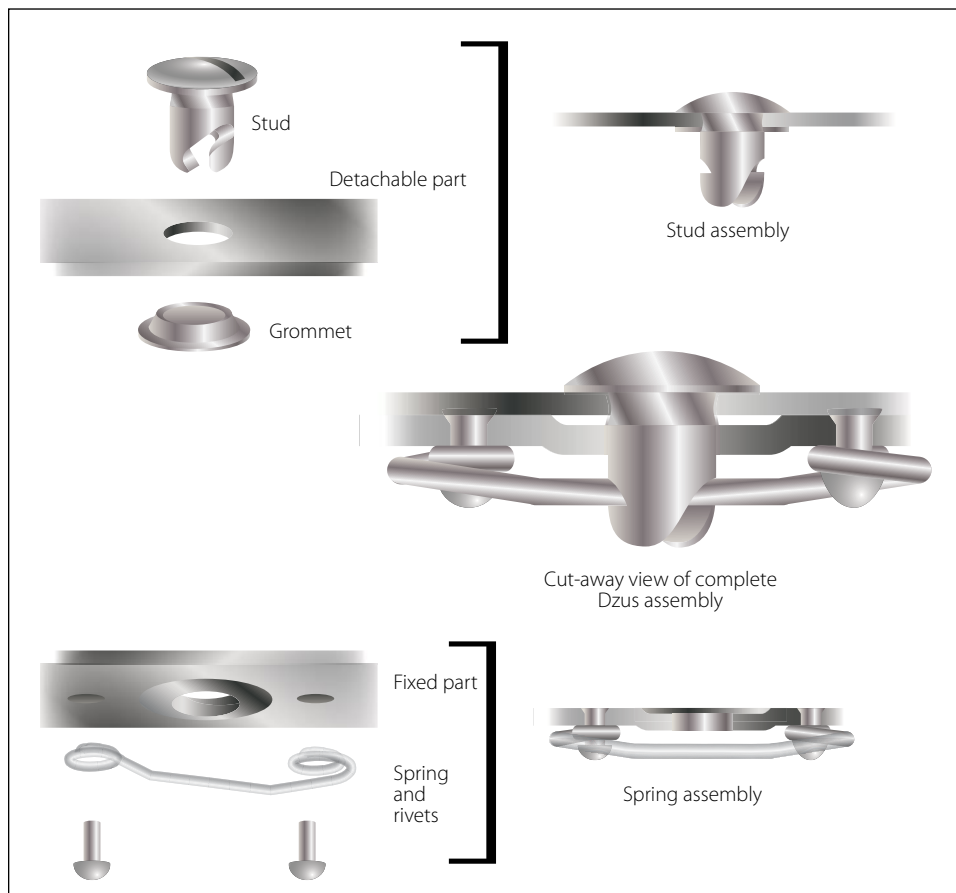

Figure 5-58. Dzus fastener.

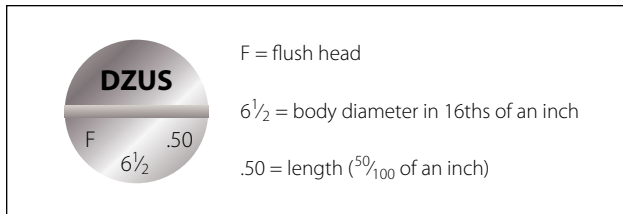

Figure 5-59. Dzus identification.

tance from the head of the stud to the bottom of the spring hole.

A quarter of a turn of the stud (clockwise) locks the fastener. The fastener may be unlocked only by turning the stud counterclockwise. A Dzus key or a specially ground screwdriver locks or unlocks the fastener.

Camloc Fasteners

Camloc fasteners are made in a variety of styles and designs. Included among the most commonly used are the 2600, 2700, 40S51, and 4002 series in the regular line, and the stressed panel fastener in the heavy duty line. The latter is used in stressed panels which carry structural loads.

The Camloc fastener is used to secure aircraft cowlings and fairings. It consists of three parts: a stud assembly, a grommet, and a receptacle. Two types of receptacles are available: rigid and floating. [Figure 5-60]

The stud and grommet are installed in the removable portion; the receptacle is riveted to the structure of the aircraft. The stud and grommet are installed in either a plain, dimpled, countersunk, or counterbored hole, depending upon the location and thickness of the material involved.

A quarter turn (clockwise) of the stud locks the fastener. The fastener can be unlocked only by turning the stud counterclockwise.

Airloc Fasteners

The Airloc fastener consists of three parts: a stud, a cross pin, and a stud receptacle. [Figure 5-61] The studs are manufactured from steel and casehardened to prevent excessive wear. The stud hole is reamed for a press fit of the cross pin.

The total amount of material thickness to be secured with the Airloc fastener must be known before the correct length of stud can be selected for installation. The total thickness of material that each stud will satisfactorily lock together is stamped on the head of the stud in thousandths of an inch (0.040, 0.070, 0.190, and

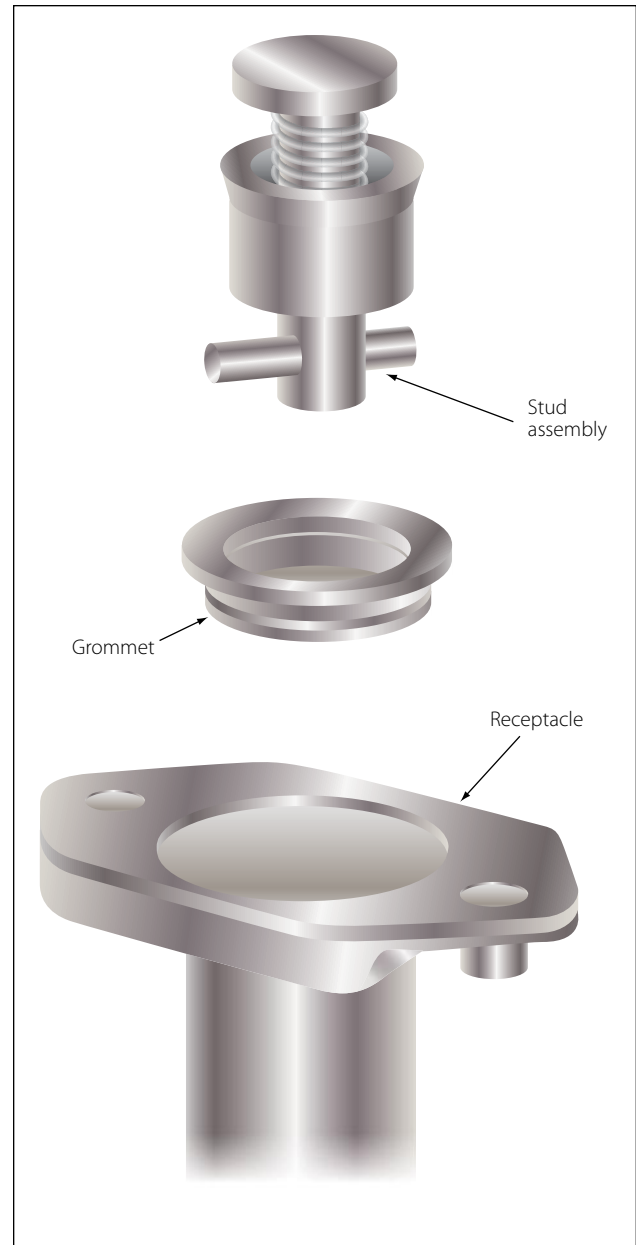

Figure 5-60. Camloc fastener.

so forth). Studs are manufactured in three head styles: flush, oval, and wing.

The cross pin [Figure 5-61] is manufactured from chrome-vanadium steel and heat treated to provide maximum strength, wear, and holding power. It should never be used the second time; once removed from the stud, replace it with a new pin.

Receptacles for Airloc fasteners are manufactured in two types: rigid and floating. Sizes are classified by number—No. 2, No. 5, and No. 7. They are also classified by the center-to-center distance between the rivet holes of the receptacle: No. 2 is $\frac{3}{4}$ inch; No. 5 is 1 inch; and No. 7 is $1\frac{3}{8}$ inch. Receptacles are fabricated from

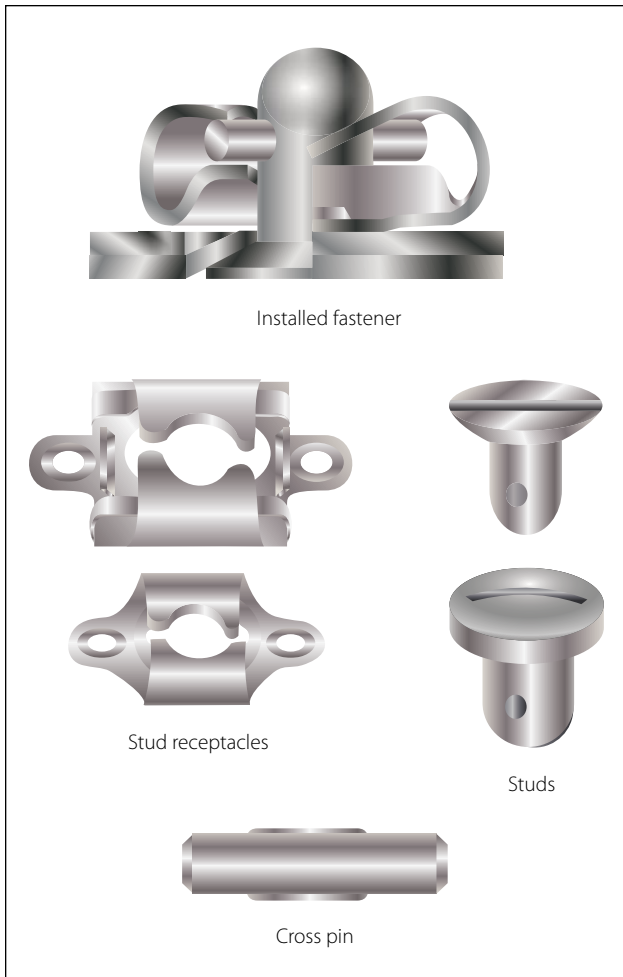

Figure 5-61. Airloc fastener.

high-carbon, heat-treated steel. An upper wing assures ejection of the stud when unlocked and enables the cross pin to be held in a locked position between the upper wing, cam, stop, and wing detent, regardless of the tension to which the receptacle is subjected.

Screws

Screws are the most commonly used threaded fastening devices on aircraft. They differ from bolts inasmuch as they are generally made of lower strength materials. They can be installed with a loose fitting thread, and the head shapes are made to engage a screwdriver or wrench. Some screws have a clearly defined grip or unthreaded portion while others are threaded along their entire length.

Several types of structural screws differ from the standard structural bolts only in head style. The material in them is the same, and a definite grip length is provided. The AN525 washer head screw and the NAS220 through NAS227 series are such screws.

Commonly used screws are classified in three groups: (1) structural screws, which have the same strength as equal size bolts; (2) machine screws, which include the majority of types used for general repair; and (3) self-tapping screws, which are used for attaching lighter parts. A fourth group, drive screws, are not actually screws but nails. They are driven into metal parts with a mallet or hammer and their heads are not slotted or recessed.

Structural Screws

Structural screws are made of alloy steel, are properly heat treated, and can be used as structural bolts. These screws are found in the NAS204 through NAS235 and AN509 and AN525 series. They have a definite grip and the same shear strength as a bolt of the same size. Shank tolerances are similar to AN hex head bolts, and the threads are National Fine. Structural screws are available with round, brazier, or countersunk heads. The recessed head screws are driven by either a Phillips or a Reed & Prince screwdriver.

The AN509 (100°) flathead screw is used in countersunk holes where a flush surface is necessary.

The AN525 washer head structural screw is used where raised heads are not objectionable. The washer head screw provides a large contact area.

Machine Screws

Machine screws are usually of the flathead (countersunk), roundhead, or washer head types. These are general purpose screws and are available in low carbon steel, brass, corrosion-resistant steel, and aluminum alloy.

Roundhead screws, AN515 and AN520, have either slotted or recessed heads. The AN515 screw has coarse threads, and the AN520 has fine threads.

Countersunk machine screws are listed as AN505 and AN510 for 82°, and AN507 for 100°. The AN505 and AN510 correspond to the AN515 and AN520 roundhead in material and usage.

The fillister head screw, AN500 through AN503, is a general purpose screw and is used as a cap screw in light mechanisms. This could include attachments of cast aluminum parts such as gearbox cover plates.

The AN500 and AN501 screws are available in low carbon steel, corrosion-resistant steel, and brass. The AN500 has coarse threads, while the AN501 has fine threads. They have no clearly defined grip length.

Screws larger than No. 6 have a hole drilled through the head for safetying purposes.

The AN502 and AN503 fillister head screws are made of heat-treated alloy steel, have a small grip, and are available in fine and coarse threads. These screws are used as capscrews where great strength is required. The coarse threaded screws are commonly used as capscrews in tapped aluminum alloy and magnesium castings because of the softness of the metal.

Self-Tapping Screws

Machine *self-tapping screws* are listed as AN504 and AN506. The AN504 screw has a roundhead, and the AN506 is 82° countersunk. These screws are used for attaching removable parts, such as nameplates, to castings and parts in which the screw cuts its own threads.

AN530 and AN531 self-tapping sheet metal screws, such as the Parker-Kalon Z-type sheet metal screw, are blunt on the end. They are used in the temporary attachment of metal for riveting, and in the permanent assembly of nonstructural assemblies. Self-tapping screws should not be used to replace standard screws, nuts, bolts, or rivets.

Drive Screws

Drive screws, AN535, correspond to the Parker-Kalon U-type. They are plain head self-tapping screws used as capscrews for attaching nameplates in castings and for sealing drain holes in corrosion proofing tubular structures. They are not intended to be removed after installation.

Identification and Coding for Screws

The coding system used to identify screws is similar to that used for bolts. There are AN and NAS screws. NAS screws are structural screws. Part numbers 510, 515, 550, and so on, catalog screws into classes, such as roundhead, flathead, washer head, and so forth. Letters and digits indicate their material composition, length, and thickness. Examples of AN and NAS code numbers follow.

AN501B-416-7

AN = Air Force-Navy standard

501 = fillister head, fine thread

B = brass

416 = $\frac{4}{16}$ -inch diameter

7 = $\frac{7}{16}$ -inch length

The letter “D” in place of the “B” would indicate that the material is 2017-T aluminum alloy. The letter “C”

would designate corrosion resistant steel. An “A” placed before the material code letter would indicate that the head is drilled for safetying.

NAS144DH-22

NAS = National Aircraft Standard

144 = head style; diameter and thread—1/4-28
bolt, internal wrenching

DH = drilled head

22 = screw length in 16ths of an inch— $1\frac{3}{8}$
inches long

The basic NAS number identifies the part. The suffix letters and dash numbers separate different sizes, plating material, drilling specifications, and so forth. The dash numbers and suffix letters do not have standard meanings. It is necessary to refer to a specific NAS page in the Standards book for the legend.

Riveted and Rivetless Nutplates

When access to the back of a screw or bolt installation is impractical, riveted or *rivetless nutplates* are used to secure the connection of panels. One example in aircraft this technique is especially useful is to secure the floorboards to the stringers and to each other.

Nutplates

Nuts that are made to be riveted in place in aircraft are called nutplates. Their purpose is to allow bolts and screws to be inserted without having to hold the nut. They are permanently mounted to enable inspection panels and access doors to be easily removed and installed. When many screws are used on a panel, to make installation easier, normally floating anchor nuts are used. The floating anchor nut fits into a small bracket which is riveted to the aircraft skin. The nut is free to move, which makes it much easier to align it with the screw. For production ease, sometimes ganged anchor nuts are used for inspection panels. Ganged anchor nuts allow the nuts to float in a channel, making alignment with the screw easy.

Self-locking nutplates are made under several standards and come in several shapes and sizes. Figure 5-62 shows an MS21078 two-lug nutplate with a nonmetallic insert, and an MS21047 lightweight, all-metal, 450 °F (232 °C) nutplate. Nutplates can also have three riveting points if the added strength is required.

Rivnuts

This is the trade name of a hollow, blind rivet made of 6053 aluminum alloy, counterbored and threaded on the inside. Rivnuts can be installed by one person using

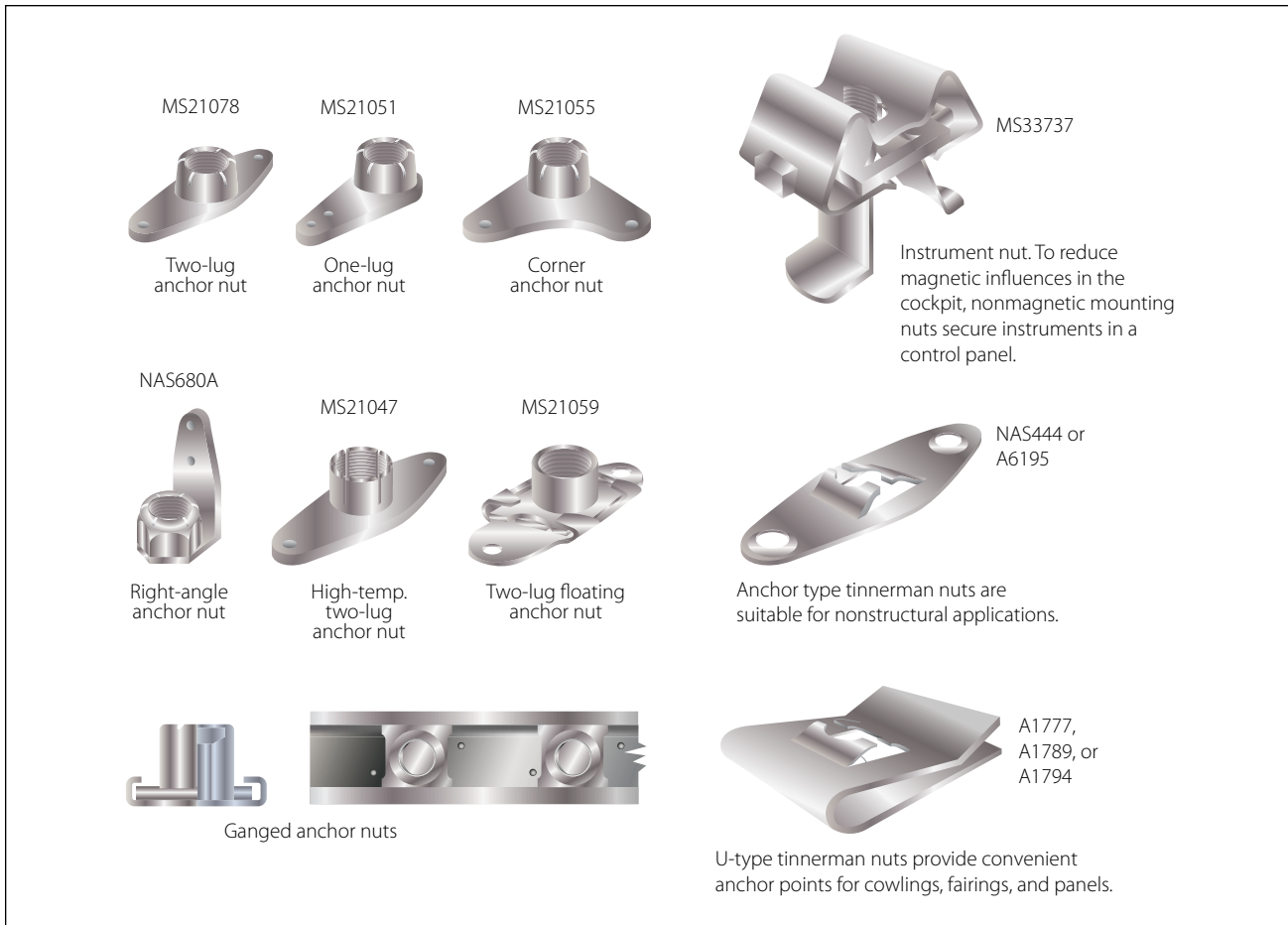

Figure 5-62. Various nutplates.

a special tool which heads the rivet on the blind side of the material. The Rivnut is threaded on the mandrel of the heading tool and inserted in the rivet hole. The heading tool is held at right angles to the material, the handle is squeezed, and the mandrel crank is turned clockwise after each stroke. Continue squeezing the handle and turning the mandrel crank of the heading tool until a solid resistance is felt, which indicates that the rivet is set.

The Rivnut is used primarily as a nut plate and in the attachment of deicer boots to the leading edges of wings. It may be used as a rivet in secondary structures or for the attachment of accessories such as brackets, fairings, instruments, or soundproofing materials.

Rivnuts are manufactured in two head types, each with two ends: the flathead with open or closed end, and the countersunk head with open or closed end. All Rivnuts, except the thin head countersunk type, are available with or without small projections (keys) attached to the head to keep the Rivnut from turning. Keyed Rivnuts are used as a nut plate, while those without keys are used for straight blind riveting repairs where no torque

loads are imposed. A keyway cutter is needed when installing Rivnuts which have keys.

The countersunk style Rivnut is made with two different head angles: the 100° with 0.048 and 0.063 inch head thickness, and the 115° with 0.063 inch head thickness. Each of these head styles is made in three sizes: 6-32, 8-32, and 10-32. These numbers represent the machine screw size of the threads on the inside of the Rivnut. The actual outside diameters of the shanks are $\frac{3}{16}$ inch for the 6-32 size, $\frac{7}{32}$ inch for the 8-32 size, and $\frac{1}{4}$ inch for the 10-32 size.

Open end Rivnuts are the most widely used and are recommended in preference to the closed end type wherever possible. However, closed end Rivnuts must be used in pressurized compartments.

Rivnuts are manufactured in six grip ranges. The minimum grip length is indicated by a plain head, and the next higher grip length by one radial dash mark on the head. Each succeeding grip range is indicated by an additional radial dash mark until five marks indicate the maximum range.

Flat — 0.32 Head Thickness		
6-45	6-75	6-100
8-45	8-75	8-100
10-45	10-75	10-100
6B45	6B75	6B100
8B45	8B75	8B100
10B45	10B75	10B100
6K45	6K75	6K100
8K45	8K75	8K100
10K45	10K75	10K100
6KB45	6KB75	6KB100
8KB45	8KB75	8KB100
10KB45	10KB75	10KB100
100° — 0.48 Head Thickness		
6-91	6-121	6-146
8-91	8-121	8-146
10-91	10-121	10-146
6B91	6B121	6B146
8B91	8B121	8B146
10B91	10B121	10B146
100° — 0.63 Head Thickness		
6-106	6-136	6-161
8-106	8-136	8-161
10-106	10-136	10-161
6B106	6B136	6B161
8B106	8B136	8B161
10B106	10B136	10B161
6K106	6K136	6K161
8K106	8K136	8K161
10K106	10K136	10K161
6KB106	6KB136	6KB161
8KB106	8KB136	8KB161
10KB106	10KB136	10KB161

Figure 5-63. Rivnut data chart.

Notice in Figure 5-63 that some part number codes consist of a “6,” an “8,” or a “10,” a “dash,” and two or three more numbers. In some, the dash is replaced by the letters “K” or “KB.” The first number indicates the machine screw size of the thread, and the last two or three numbers indicate the maximum grip length in thousandths of an inch. A dash between the figures indicates that the Rivnut has an open end and is keyless; a “B” in place of the dash means it has a closed end and is keyless; a “K” means it has an open end and has a key; and a “KB” indicates that it has a closed end and a key. If the last two or three numbers are divisible by five, the Rivnut has a flathead; if they are not divisible by five, the Rivnut has a countersunk head.

An example of a part number code is:

10KB106

10 = Grip length

KB = Closed end and key

106 = Screw and thread size

Dill Lok-Skrus and Dill Lok-Rivets

Dill “Lok-Skru” and “Lok-Rivet” are trade names for internally threaded rivets. They are used for blind attachment of such accessories as fairings, fillets, access door covers, door and window frames, floor panels, and the like. Lok-Skrus and Lok-Rivets are similar to the Rivnut in appearance and application; however, they come in two parts and require more clearance on the blind side than the Rivnut to accommodate the barrel. [Figure 5-64]

The Lok-Rivet and the Lok-Skru are alike in construction, except the Lok-Skru is tapped internally for fastening an accessory by using an attaching screw, whereas the Lok-Rivet is not tapped and can be used only as a rivet. Since both Lok-Skrus and Lok-Rivets

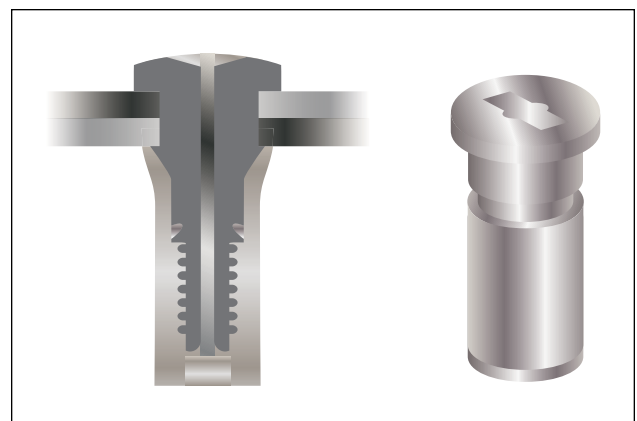

Figure 5-64. Internally threaded rivet (Rivnut).

are installed in the same manner, the following discussions for the Lok-Skru also applies to the Lok-Rivet.

The main parts of a Lok-Skru are the barrel, the head, and an attachment screw. The barrel is made of aluminum alloy and comes in either closed or open ends. The head is either aluminum alloy or steel, and the attachment screw is made of steel. All of the steel parts are cadmium plated, and all of aluminum parts are anodized to resist corrosion. When installed, the barrel screws up over the head and grips the metal on the blind side. The attaching screw is then inserted if needed. There are two head types: the flathead and the countersunk head. The Lok-Skru is tapped for 7-32, 8-32, 10-32, or 10-24 screws, and the diameters vary from 0.230 inch for 6-32 screws, to 0.292 inch for 10-32 screws. Grip ranges vary from 0.010 inch to 0.225 inch.

Deutsch Rivets

This rivet is a high strength blind rivet used on late model aircraft. It has a minimum shear strength of 75,000 psi, and can be installed by one person. The Deutsch rivet consists of two parts: the stainless steel sleeve and the hardened steel drive pin. [Figure 5-65] The pin and sleeve are coated with a lubricant and a corrosion inhibitor.

The Deutsch rivet is available in diameters of $\frac{3}{16}$, $\frac{1}{4}$, or $\frac{3}{8}$ inch. Grip lengths for this rivet range from $\frac{3}{16}$ to 1 inch. Some variation is allowed in grip length when installing the rivet; for example, a rivet with a grip length of $\frac{3}{16}$ inch can be used where the total thickness of materials is between 0.198 and 0.228 inch.

When driving a Deutsch rivet, an ordinary hammer or a pneumatic rivet gun and a flathead set are used. The rivet is seated in the previously drilled hole and then the pin is driven into the sleeve. The driving action causes the pin to exert pressure against the sleeve and

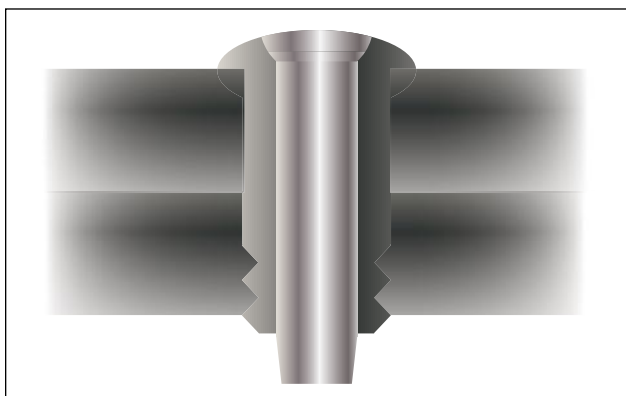

Figure 5-65. Deutsch rivet.

forces the sides of the sleeve out. This stretching forms a shop head on the end of the rivet and provides positive fastening. The ridge on the top of the rivet head locks the pin into the rivet as the last few blows are struck.

Sealing Nutplates

When securing nutplates in pressurized aircraft and in fuel cells, a sealing nutplate is used instead of the open ended variety previously described. Care must be taken to use exactly the correct length of bolt or screw. If a bolt or screw is too short, there will not be enough threads to hold the device in place. If the bolt or screw is too long, it will penetrate the back side of the nutplate and compromise the seal. Normally, a sealant is also used to ensure complete sealing of the nutplate. Check the manufacturer's specifications for the acceptable sealant to be used for sealing nutplates.

Hole Repair and Hole Repair Hardware

Many of the blind fasteners are manufactured in oversized diameters to accommodate slightly enlarged holes resulting from drilling out the original fastener. When using rivets or even bolts, care must be taken to ensure the hole is not elongated or slanted.

To reduce the chances of an incorrectly drilled rivet or bolt hole, use a slightly smaller drill bit first, then enlarge to the correct diameter. The last step to prepare the hole for the fastener is to deburr the hole using either a very large drill bit or a special deburring tool. This practice also works well when drilling out a previously attached fastener. If the drill bit does not exactly find the center of the rivet or bolt or screw, the hole can easily be elongated, but when using a smaller drill bit, drill the head only off the fastener, then the ring and stem that is left can be pushed out with a pin punch of the appropriate diameter. If an incorrectly drilled hole is found, the options are to redrill the hole to the next larger diameter for an acceptable fastener or repair the hole using an Acres fastener sleeve.

Repair of Damaged Holes with Acres Fastener Sleeves

Acres fastener sleeves are thin-wall tubular elements with a flared end. The sleeves are installed in holes to accept standard bolts and rivet-type fasteners. The existing fastener holes are drilled $\frac{1}{64}$ inch oversize for installation of the sleeves. The sleeves are manufactured in 1-inch increments. Along their length, grooves provide a place to break or cut off excess length to match fastener grip range. The grooves also provide a place to hold adhesive or sealing agents when bonding the sleeve into the hole.

Advantages and Limitations

The sleeves are used in holes which must be drilled $\frac{1}{64}$ inch oversize to clean up corrosion or other damage. The oversize hole with the sleeve installed allows the use of the original diameter fastener in the repaired hole. The sleeves can be used in areas of high galvanic corrosion where the corrosion must be confined to a readily replaceable part. Oversizing of holes reduces the net cross-sectional area of a part and should not be done unless absolutely required.

Consult the manufacturer of the aircraft, aircraft engine or aircraft component prior to repair of damaged holes with Acres sleeves.

Identification

The sleeve is identified by a standard code number [Figure 5-66A] which represents the type and style of sleeve, a material code, the fastener shank diameter, surface finish code letter and grip tang for the sleeve. The type and material of the sleeve is represented by the basic code number. The first dash number represents the diameter of the sleeve for the fastener installed and the second dash represents the grip length of the sleeve. The required length of the sleeve is determined on installation and the excess is broken off of the sleeve. A JK5512A-05N-10 is a 100° low profile head sleeve of aluminum alloy. The diameter is for a $\frac{5}{32}$ -inch fastener with no surface finish and is $\frac{5}{8}$ inch in length.

Hole Preparation

Refer to Figure 5-66B for drill number for standard or close fit holes. Inspect hole after drilling to assure all corrosion is removed before installing the sleeve. The hole must also be the correct shape and free from burrs. The countersink must be enlarged to receive the flare of the sleeve so the sleeve is flush with the surrounding surface.

Installation

After selecting the correct type and diameter sleeve, use the 6501 sleeve breakoff tool for final installation length. Refer to Figure 5-66B for the sleeve breakoff procedure. The sleeve may be installed with or without being bonded in the hole. When bonding the sleeve in a hole, use MIL-S-8802A $\frac{1}{2}$ sealant. Reinstall original size fastener and torque as required.

Sleeve Removal

Sleeves not bonded in the hole may be removed by either driving them out with a drift pin of the same diameter as the outside diameter of the sleeve or they may be deformed and removed with a pointed tool. Bonded sleeves may be removed by this method, but

care should be used not to damage the structure hole. If this method cannot be used, drill the sleeves out with a drill 0.004 to 0.008 inch smaller than the installation drill size. The remaining portion of the sleeve after drilling can be removed using a pointed tool and applying an adhesive solvent to the sealant.

Control Cables and Terminals

Cables are the most widely used linkage in primary flight control systems. Cable-type linkage is also used in engine controls, emergency extension systems for the landing gear, and various other systems throughout the aircraft.

Cable-type linkage has several advantages over the other types. It is strong and light weight, and its flexibility makes it easy to route through the aircraft. An aircraft cable has a high mechanical efficiency and can be set up without backlash, which is very important for precise control.

Cable linkage also has some disadvantages. Tension must be adjusted frequently due to stretching and temperature changes.

Aircraft control cables are fabricated from carbon steel or stainless steel.

Cable Construction

The basic component of a cable is a wire. The diameter of the wire determines the total diameter of the cable. A number of wires are preformed into a helical or spiral shape and then formed into a strand. These preformed strands are laid around a straight center strand to form a cable.

Cable designations are based on the number of strands and the number of wires in each strand. The most common aircraft cables are the 7×7 and 7×19 .

The 7×7 cable consists of seven strands of seven wires each. Six of these strands are laid around the center strand. [Figure 5-67] This is a cable of medium flexibility and is used for trim tab controls, engine controls, and indicator controls.

The 7×19 cable is made up of seven strands of 19 wires each. Six of these strands are laid around the center strand. [Figure 5-67] This cable is extra flexible and is used in primary control systems and in other places where operation over pulleys is frequent.

Aircraft control cables vary in diameter, ranging from $\frac{1}{16}$ to $\frac{3}{8}$ inch. The diameter is measured as shown in Figure 5-67.

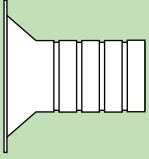
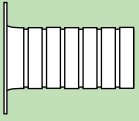
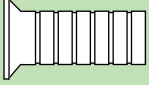
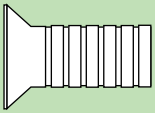
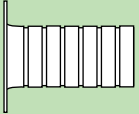
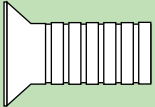
Acres Sleeve	Type	Basic Part Number
	100° Tension head plus flange (509 type)	JK5610
	Protruding head (shear)	JK5511
	100° Low profile head	JK5512
	100° Standard profile head (509 type)	JK5516
	Protruding head (tension)	JK5517
	100° Oversize tension head ($1/64$ oversize bolt)	JK5533

Part Number Breakdown

JK5511 A 04 N 08 L

JK5511 | Basic part number

A | Material Code ¹

04 | Fastener shank diameter in 32nds

N | Surface finish
N = No finish
C = Chemical film per MIL-C-554

08 | Length in sixteenth-inch increments
(required installation length by breaking off at proper groove)

L | "L" at end of part number indicates cetyl alcohol lubricant

Material	Material Code
5052 Aluminium alloy $1/2$ hard	A
6061 Aluminium alloy (T6 condition)	B
A286 Stainless steel (passivate)	C

Sleeve Part No.	Bolt Size	² Sleeve Length
JK5511()04() JK5512()04() JK5516()04() JK5517()04()	$1/8$	8
JK5511()45() JK5512 JK5516()45() JK5517()45()	#6	8
JK5511()05() JK5512()05() JK5516()05() JK5517()05()	$5/32$	10
JK5511()55() JK5512()55() JK5516()55() JK5517()55() JK5610()55()	#8	10
JK5511()06() JK5512()06() JK5516()06() JK5517()06() JK5610()06()	#10	12
JK5511()08() JK5512()08() JK5516()08() JK5517()08() JK5610()08()	$1/4$	16
JK5511()10() JK5512()10() JK5516()10() JK5517()10() JK5610()10()	$5/16$	16
JK5511()12() JK5512()12() JK5516()12() JK5517()12() JK5610()12()	$3/8$	16

Acres Sleeve for $1/64$ Oversize Bolt

¹ Sleeve Part No.	Bolt Size	² Sleeve Length
JK5533()06()	$13/64$	12
JK5533()08()	$17/64$	16
JK5533()10()	$21/64$	16
JK5533()12()	$25/64$	16

Notes:

¹ Acres sleeve, JK5533 $1/64$ oversize available in A286 steel only

² Acres sleeve length in sixteenth-inch increments

Figure 5-66A. Acres sleeve identification.

Hole Preparation for 1/64 Oversize Bolt

Bolt Size	Drill No.	Drill Dia.
13/64	7/32	0.2187
17/64	9/32	0.2812
21/64	11/32	0.3437
25/64	13/32	0.4062

Hole Preparation

Bolt Size	Standard Fit		Close Fit	
	Drill No.	Drill Dia.	Drill No.	Drill Dia.
1/8	9/64	0.1406	28	0.1405
#6	23	0.1540	24	0.1520
5/32	11/64	0.1719	18	0.1695
#8	15	0.1800	16	0.1770
#10	5	0.2055	6	0.2040
1/4	14	0.2660	17/64	0.2656
5/16	21/64	0.3281		
3/8	25/64	0.3908		

Installation Procedure

- Drill out corrosion or damage to existing hole to 1/64 oversize.
- Select proper type and length acres sleeve for existing fastener.
- Bond sleeve in structure hole with MIL-S-8802 class A 1/2 sealant.

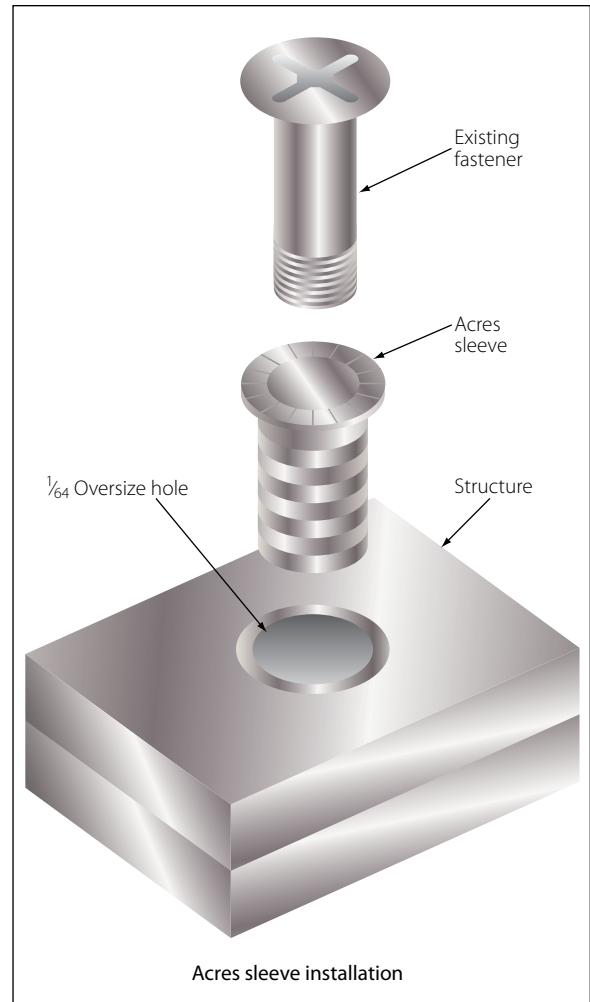

Figure 5-66B. Acres sleeve identification, installation, and breakoff procedure.

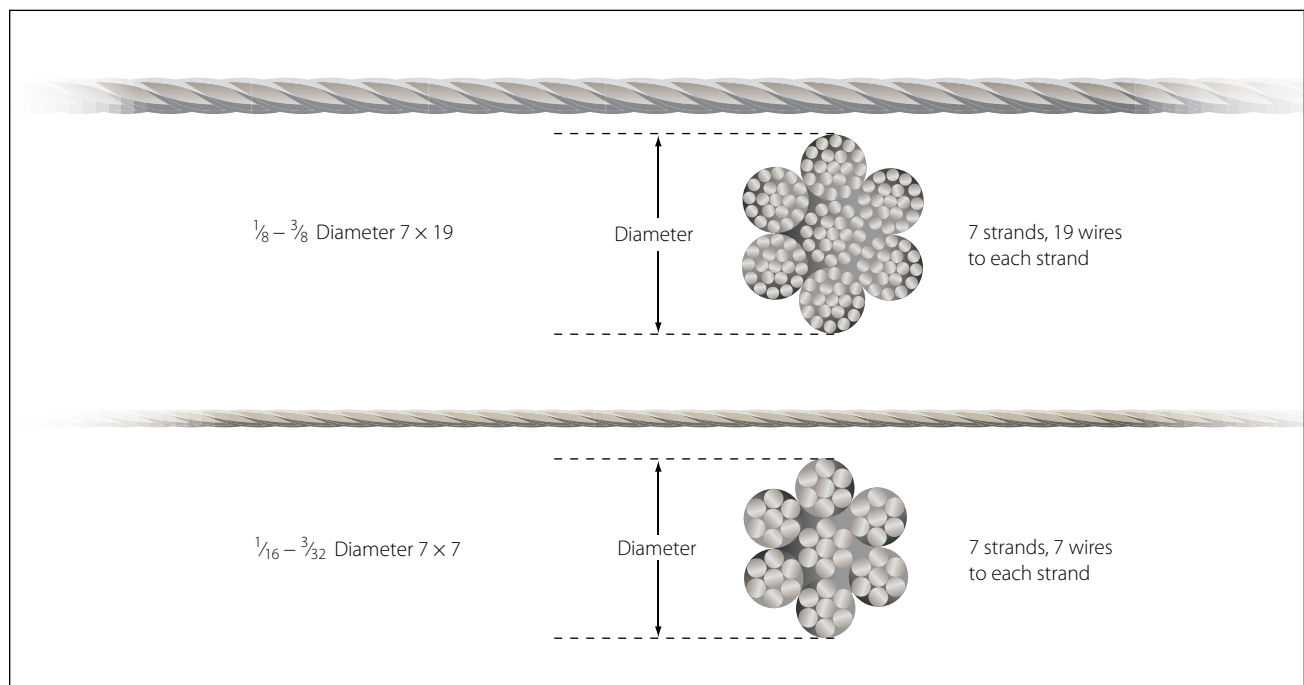

Figure 5-67. Cable cross sections.

Cable Fittings

Cables may be equipped with several different types of fittings, such as terminals, thimbles, bushings, and shackles.

Terminal fittings are generally of the swaged type. They are available in the threaded end, fork end, eye end, single shank ball end, and double shank ball end. The threaded end, fork end, and eye end terminals are used to connect the cable to a turnbuckle, bellcrank, or other linkage in the system. The ball end terminals are used for attaching cables to quadrants and special connections where space is limited. Figure 5-68 illustrates the various types of terminal fittings.

The thimble, bushing, and shackle fittings may be used in place of some types of terminal fittings when facilities and supplies are limited and immediate replacement of the cable is necessary.

Turnbuckles

A turnbuckle assembly is a mechanical screw device consisting of two threaded terminals and a threaded barrel. [Figure 5-69]

Turnbuckles are fitted in the cable assembly for the purpose of making minor adjustments in cable length and for adjusting cable tension. One of the terminals has right-hand threads and the other has left-hand threads. The barrel has matching right- and left-hand internal threads. The end of the barrel with the left-hand threads can usually be identified by a groove or knurl around that end of the barrel.

When installing a turnbuckle in a control system, it is necessary to screw both of the terminals an equal number of turns into the barrel. It is also essential that all turnbuckle terminals be screwed into the barrel until not more than three threads are exposed on either side of the turnbuckle barrel.

After a turnbuckle is properly adjusted, it must be safetied. The methods of safetying turnbuckles are discussed later in this chapter.

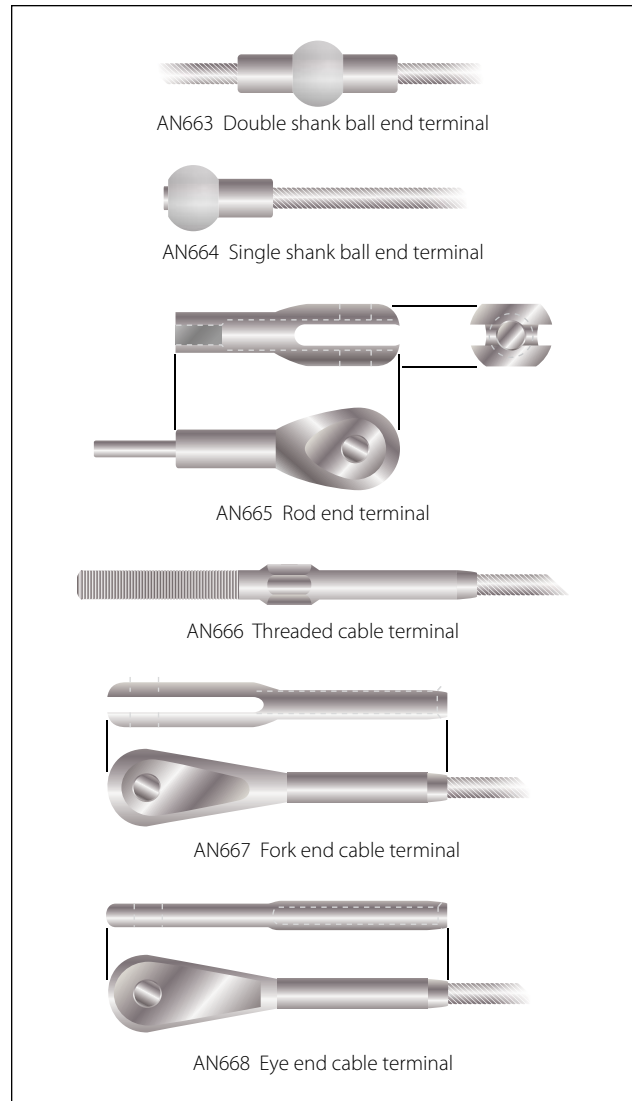

Figure 5-68. Types of terminal fittings.

Push-Pull Tube Linkage

Push-pull tubes are used as linkage in various types of mechanically operated systems. This type linkage eliminates the problem of varying tension and permits the transfer of either compression or tension stress through a single tube.

A push-pull tube assembly consists of a hollow aluminum alloy or steel tube with an adjustable end fitting

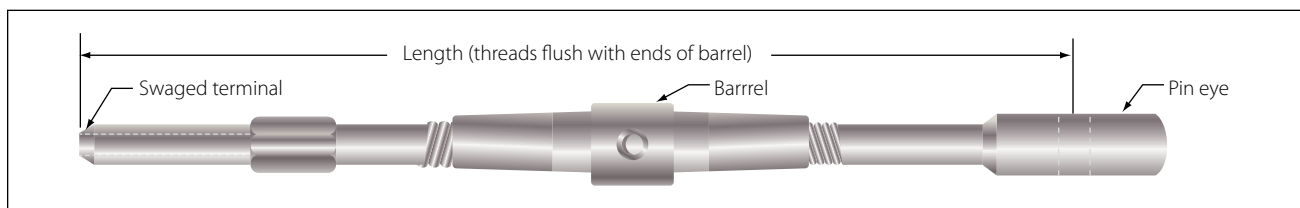

Figure 5-69. Typical turnbuckle assembly.

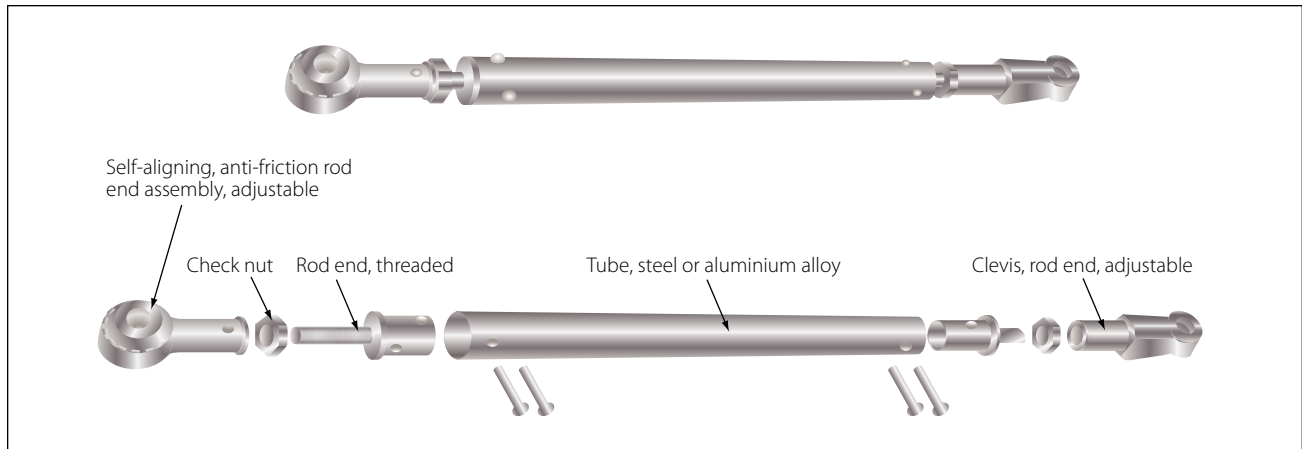

Figure 5-70. Push-pull tube assembly.

and a checknut at either end. [Figure 5-70] The checknuts secure the end fittings after the tube assembly has been adjusted to its correct length. Push-pull tubes are generally made in short lengths to prevent vibration and bending under compression loads.

Safetying Methods

To ensure fasteners do not separate from their nuts or holding ends, various safetying methods are used in aircraft from heavy aircraft to gliders to recreational aircraft.

Safetying is the process of securing all aircraft, bolts, nuts, screws, pins, and other fasteners so that they do not work loose due to vibration. A familiarity with the various methods and means of safetying equipment on an aircraft is necessary in order to perform maintenance and inspection.

There are various methods of safetying aircraft parts. The most widely used methods are safety wire, cotter pins, lockwashers, snaprings, and special nuts, such as self-locking nuts, pal nuts, and jamnuts. Some of these nuts and washers have been previously described in this chapter.

Pins

The three main types of pins used in aircraft structures are the taper pin, flathead pin, and cotter pin. Pins are used in shear applications and for safetying. Roll pins are finding increasing uses in aircraft construction.

Taper Pins

Plain and threaded taper pins (AN385 and AN386) are used in joints which carry shear loads and where absence of play is essential. The plain taper pin is drilled and usually safetyed with wire. The threaded taper pin is used with a taper pin washer (AN975) and

shear nut (safetyed with a cotter pin or safety clip) or self-locking nut.

Flathead Pin

Commonly called a clevis pin, the flathead pin (MS20392) is used with tie rod terminals and in secondary controls which are not subject to continuous operation. The pin is customarily installed with the head up so that if the cotter pin fails or works out, the pin will remain in place.

Cotter Pins

The AN380 cadmium plated, low carbon steel cotter pin is used for safetying bolts, screws, nuts, other pins, and in various applications where such safetying is necessary. The AN381 corrosion resistant steel cotter pin is used in locations where nonmagnetic material is required, or in locations where resistance to corrosion is desired.

Roll Pins

The roll pin is a pressed fit pin with chamfered ends. It is tubular in shape and is slotted the full length of the tube. The pin is inserted with hand tools and is compressed as it is driven into place. Pressure exerted by the roll pin against the hole walls keeps it in place, until deliberately removed with a drift punch or pin punch.

Safety Wiring

Safety wiring is the most positive and satisfactory method of safetying capscrews, studs, nuts, bolt heads, and turnbuckle barrels which cannot be safetyed by any other practical means. It is a method of wiring together two or more units in such a manner that any tendency of one to loosen is counteracted by the tightening of the wire.

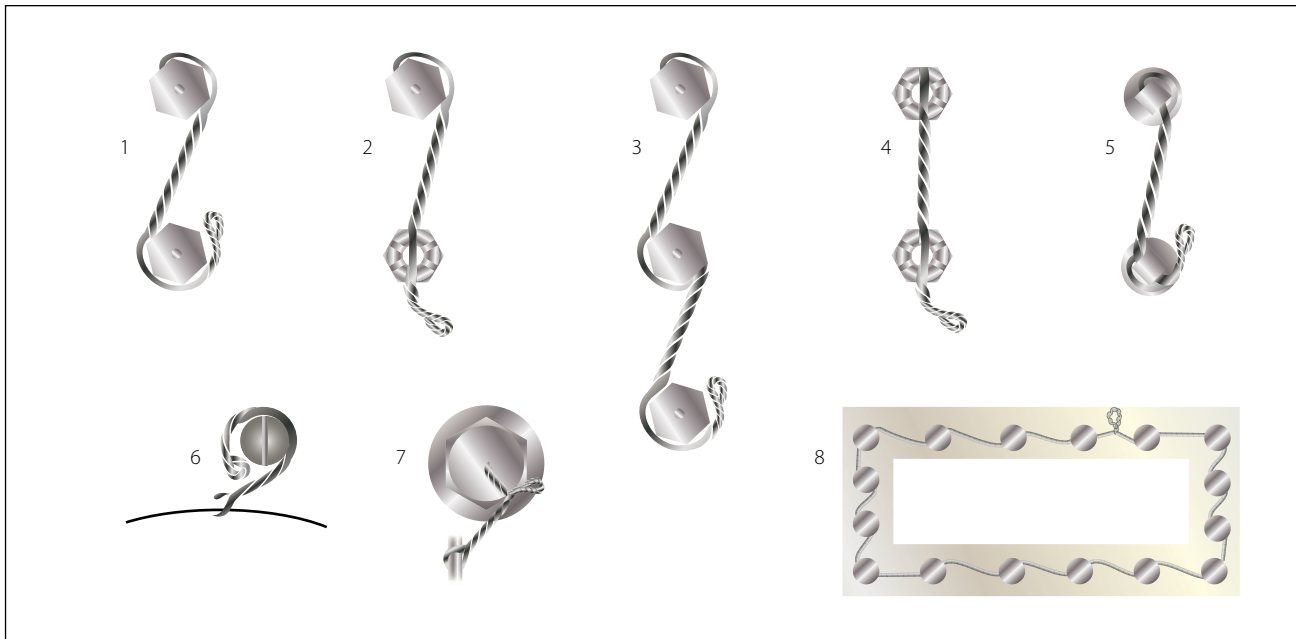

Figure 5-71. Safety wiring methods.

Nuts, Bolts, and Screws

Nuts, bolts, and screws are safety wired by the single wire or double twist method. The double twist method is the most common method of safety wiring. The single wire method may be used on small screws in a closely spaced closed geometrical pattern, on parts in electrical systems, and in places that are extremely difficult to reach. Safety wiring should always be per conventional methods or as required by the manufacturer, especially for Light Sport Aircraft (LSA).

Figure 5-71 is an illustration of various methods which are commonly used in safety wiring nuts, bolts, and screws. Careful study of Figure 5-71 shows that:

- Examples 1, 2, and 5 illustrate the proper method of safety wiring bolts, screws, squarehead plugs, and similar parts when wired in pairs.
- Example 3 illustrates several components wired in series.
- Example 4 illustrates the proper method of wiring castellated nuts and studs. (Note that there is no loop around the nut.)
- Examples 6 and 7 illustrate a single threaded component wired to a housing or lug.
- Example 8 illustrates several components in a closely spaced closed geometrical pattern, using a single wire method.

When drilled head bolts, screws, or other parts are grouped together, they are more conveniently safety

wired to each other in a series rather than individually. The number of nuts, bolts, or screws that may be safety wired together is dependent on the application. For instance, when safety wiring widely spaced bolts by the double twist method, a group of three should be the maximum number in a series.

When safety wiring closely spaced bolts, the number that can be safety wired by a 24-inch length of wire is the maximum in a series. The wire is arranged so that if the bolt or screw begins to loosen, the force applied to the wire is in the tightening direction.

Parts being safety wired should be torqued to recommend values and the holes aligned before attempting the safetying operation. Never overtorque or loosen a torqued nut to align safety wire holes.

Oil Caps, Drain Cocks, and Valves

These units are safety wired as shown in Figure 5-72. In the case of the oil cap, the wire is anchored to an adjacent fillister head screw.

This system applies to any other unit which must be safety wired individually. Ordinarily, anchorage lips are conveniently located near these individual parts. When such provision is not made, the safety wire is fastened to some adjacent part of the assembly.

Electrical Connectors

Under conditions of severe vibration, the coupling nut of a connector may vibrate loose, and with sufficient vibration the connector may come apart. When this

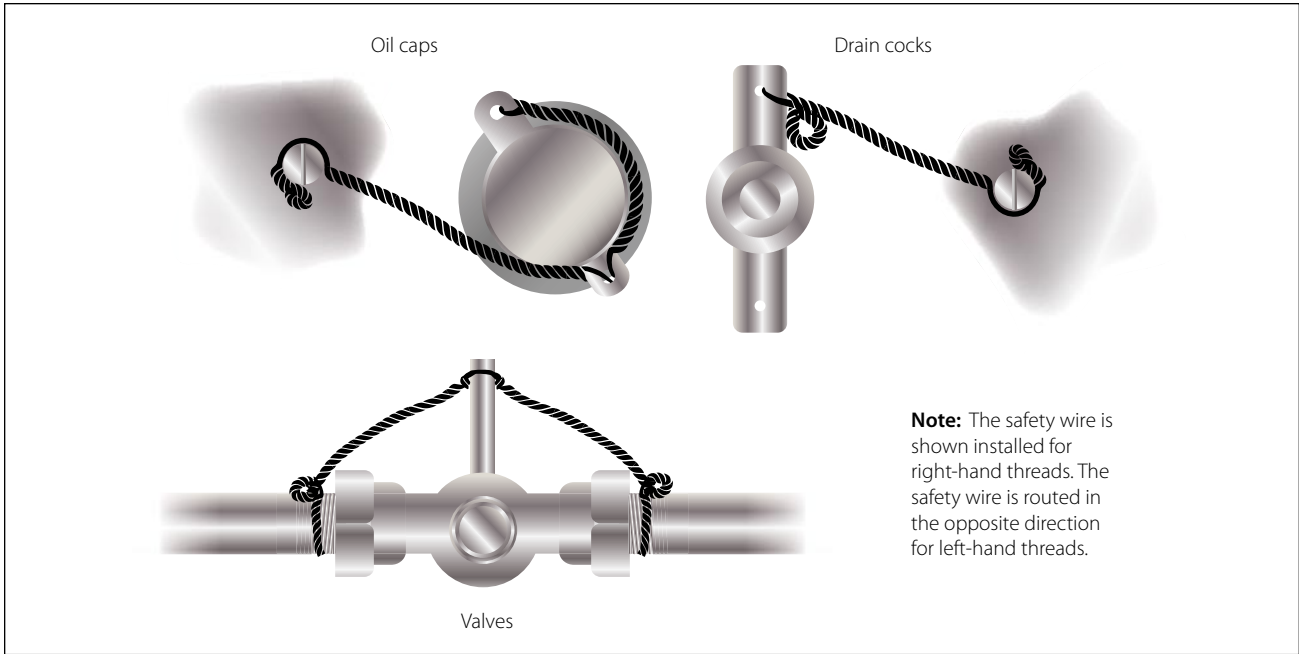

Figure 5-72. Safety wiring attachment for plug connectors.

occurs, the circuit carried by the cable opens. The proper protective measure to prevent this occurrence is by safety wiring as shown in Figure 5-73. The safety wire should be as short as practicable and must be installed in such a manner that the pull on the wire is in the direction which tightens the nut on the plug.

Turnbuckles

After a turnbuckle has been properly adjusted, it must be safetied. There are several methods of safeying

turnbuckles; however, only two methods will be discussed in this section. These methods are illustrated in Figure 5-74(A) and Figure 5-74(B). The clip locking method is used only on the most modern aircraft. The older type aircraft still use the type turnbuckles that require the wire wrapping method.

Double Wrap Method. Of the methods using safety wire for safeying turnbuckles, the double wrap method is preferred, although the single wrap methods described

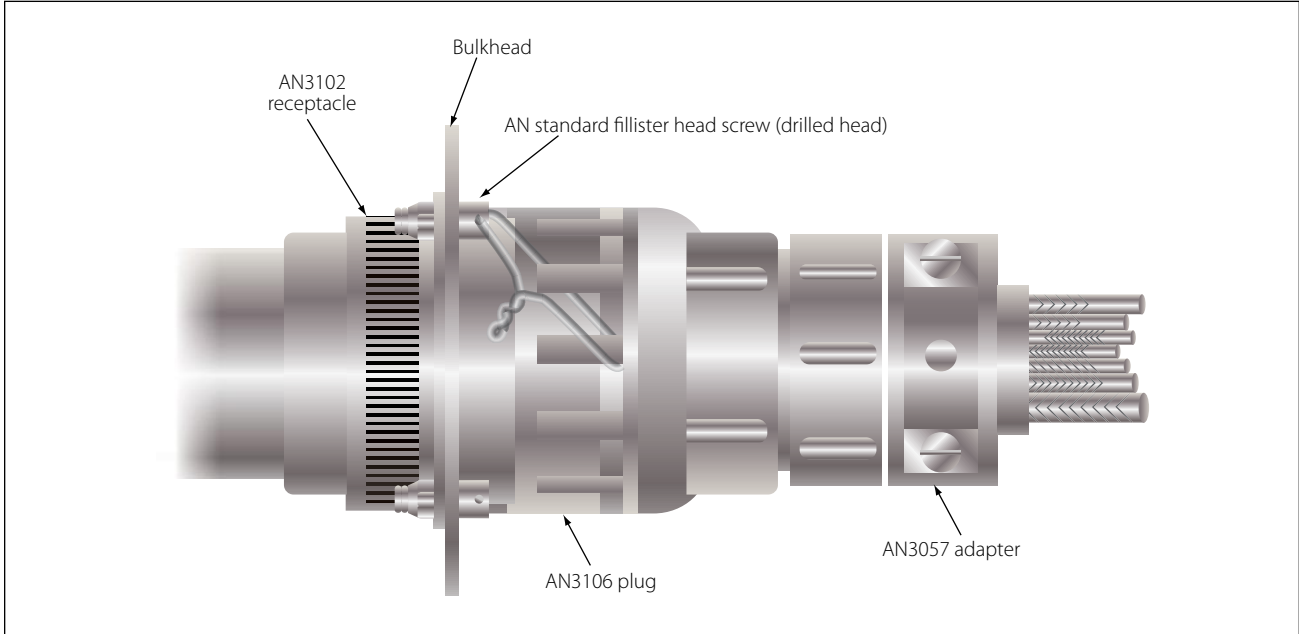

Figure 5-73. Safety wiring attachment for plug connectors.

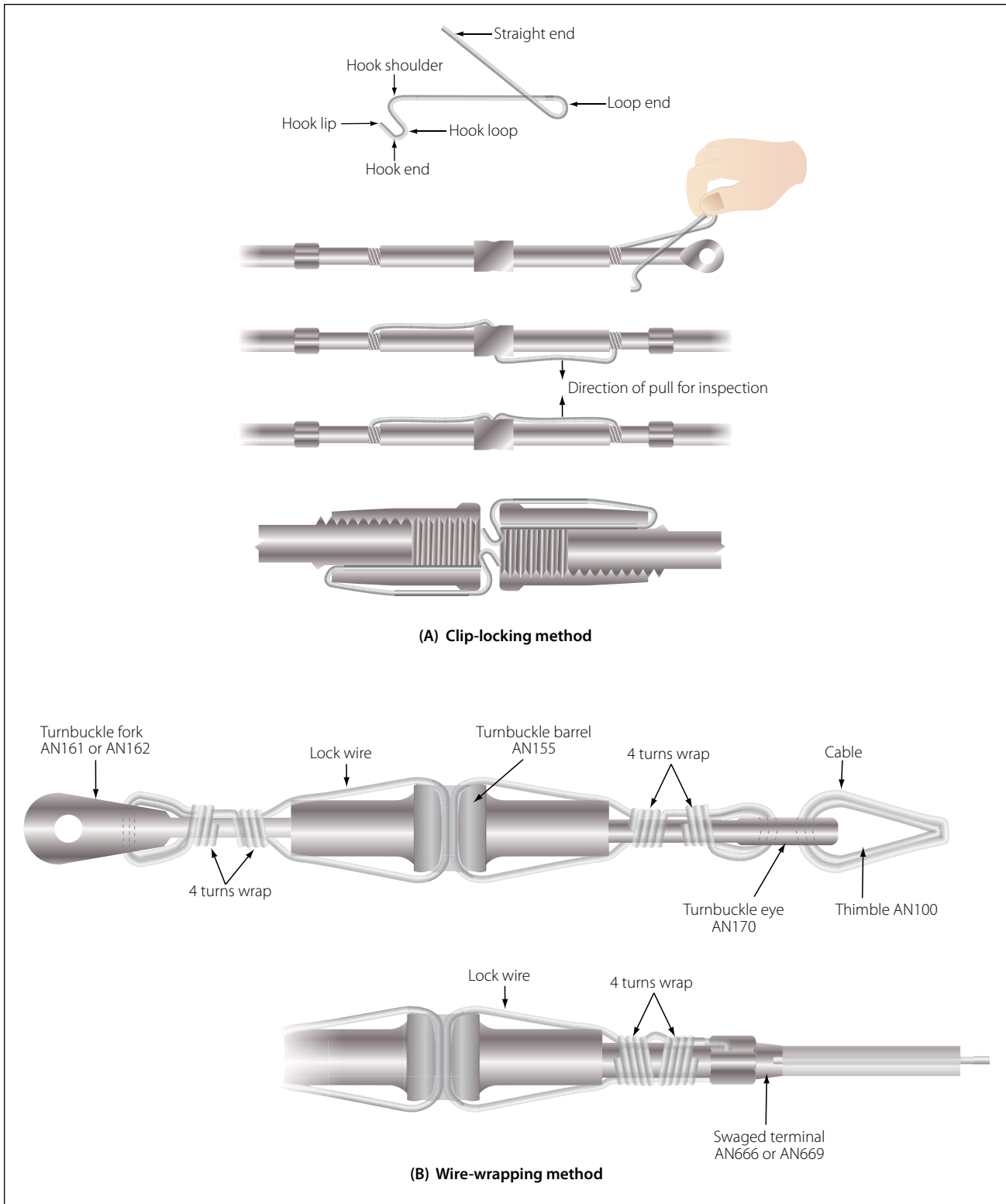

Figure 5-74. Safelying turnbuckles: (A) clip-locking method and (B) wire-wrapping method.

are satisfactory. The method of double wrap safelying is shown in Figure 5-74(B). Use two separate lengths of the proper wire as shown in Figure 5-75.

Run one end of the wire through the hole in the barrel of the turnbuckle and bend the ends of the wire toward

opposite ends of the turnbuckle. Then pass the second length of the wire into the hole in the barrel and bend the ends along the barrel on the side opposite the first. Then pass the wires at the end of the turnbuckle in opposite directions through the holes in the turnbuckle

Cable size (in)	Type of Wrap	Diameter of Safety Wire (in)	Material (Annealed Condition)
1/16	Single	.020	Stainless steel
3/32	Single	.040	Copper, brass ¹
1/8	Single	.040	Stainless steel
1/8	Double	.040	Copper, brass ¹
1/8	Single	.057 min	Copper, brass ¹
5/32 and greater	Single	.057	Stainless steel

¹ Galvanized or tinned steel, or soft iron wires are also acceptable.

Figure 5-75. Turnbuckle safetying guide.

eyes or between the jaws of the turnbuckle fork, as applicable. Bend the laid wires in place before cutting off the wrapped wire. Wrap the remaining length of safety wire at least four turns around the shank and cut it off. Repeat the procedure at the opposite end of the turnbuckle.

When a swaged terminal is being safetyed, pass the ends of both wires, if possible, through the hole provided in the terminal for this purpose and wrap both ends around the shank as described above.

If the hole is not large enough to allow passage of both wires, pass the wire through the hole and loop it over the free end of the other wire, and then wrap both ends around the shank as described.

Single Wrap Method. The single wrap safetying methods described in the following paragraphs are acceptable but are not the equal of the double wrap methods.

Pass a single length of wire through the cable eye or fork, or through the hole in the swaged terminal at either end of the turnbuckle assembly. Spiral each of the wire ends in opposite directions around the first half of the turnbuckle barrel so that the wires cross each other twice. Thread both wire ends through the hole in the middle of the barrel so that the third crossing of the wire ends is in the hole. Again, spiral the two wire ends in opposite directions around the remaining half of the turnbuckle, crossing them twice. Then, pass one wire end through the cable eye or fork, or through the hole in the swaged terminal. In the manner described above, wrap both wire ends around the shank for at least four turns each, cutting off the excess wire.

An alternate to the above method is to pass one length of wire through the center hole of the turnbuckle and

bend the wire ends toward opposite ends of the turnbuckle. Then pass each wire end through the cable eye or fork, or through the hole in the swaged terminal and wrap each wire end around the shank for at least four turns, cutting off the excess wire. After safetying, no more than three threads of the turnbuckle threaded terminal should be exposed.

General Safety Wiring Rules

When using the safety wire method of safetying, the following general rules should be followed:

1. A pigtail of 1/4 to 1/2 inch (three to six twists) should be made at the end of the wiring. This pigtail must be bent back or under to prevent it from becoming a snag.
2. The safety wire must be new upon each application.
3. When castellated nuts are to be secured with safety wire, tighten the nut to the low side of the selected torque range, unless otherwise specified, and if necessary, continue tightening until a slot aligns with the hole.
4. All safety wires must be tight after installation, but not under such tension that normal handling or vibration will break the wire.
5. The wire must be applied so that all pull exerted by the wire tends to tighten the nut.
6. Twists should be tight and even, and the wire between the nuts as taut as possible without overtwisting.
7. The safety wire should always be installed and twisted so that the loop around the head stays down and does not tend to come up over the bolt head, causing a slack loop.

Cotter Pin Safetying

Cotter pin installation is shown in Figure 5-76. Castellated nuts are used with bolts that have been drilled for cotter pins. The cotter pin should fit neatly into the hole, with very little sideplay. The following general rules apply to cotter pin safetying:

1. The prong bent over the bolt end should not extend beyond the bolt diameter. (Cut it off if necessary.)
2. The prong bent down should not rest against the surface of the washer. (Again, cut it off if necessary.)
3. If the optional wraparound method is used, the prongs should not extend outward from the sides of the nut.
4. All prongs should be bent over a reasonable radius. Sharp angled bends invite breakage. Tapping lightly with a mallet is the best method of bending the prongs.

Snaprings

A snapring is a ring of metal, either round or flat in cross section, which is tempered to have springlike action. This springlike action will hold the snapring firmly seated in a groove. The external types are designed to fit in a groove around the outside of a shaft or cylinder, and may be safety wired. Safety wiring of an external type snapring is shown in Figure 5-77. The internal types fit in a groove inside a cylinder, and are never safety wired. A special type of pliers is designed to install each type of snapring. Snaprings can be reused as long as they retain their shape and springlike action.

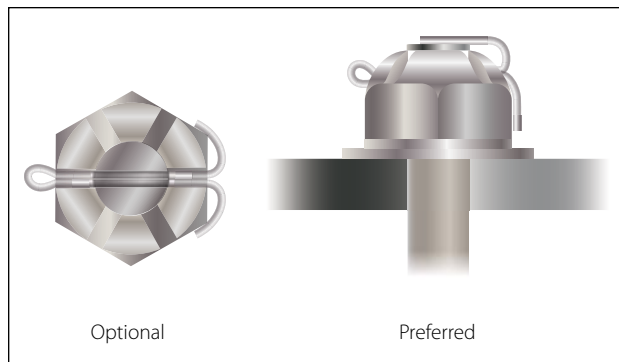

Figure 5-76. Cotter pin installations.

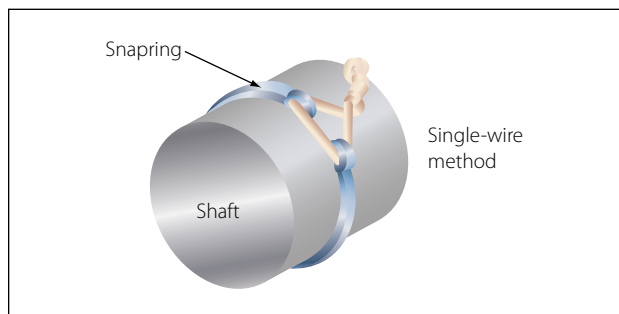

Figure 5-77. External type snapring with safety wire installation.